

LargeRotoSonic Crawler

Type: LRS FS250

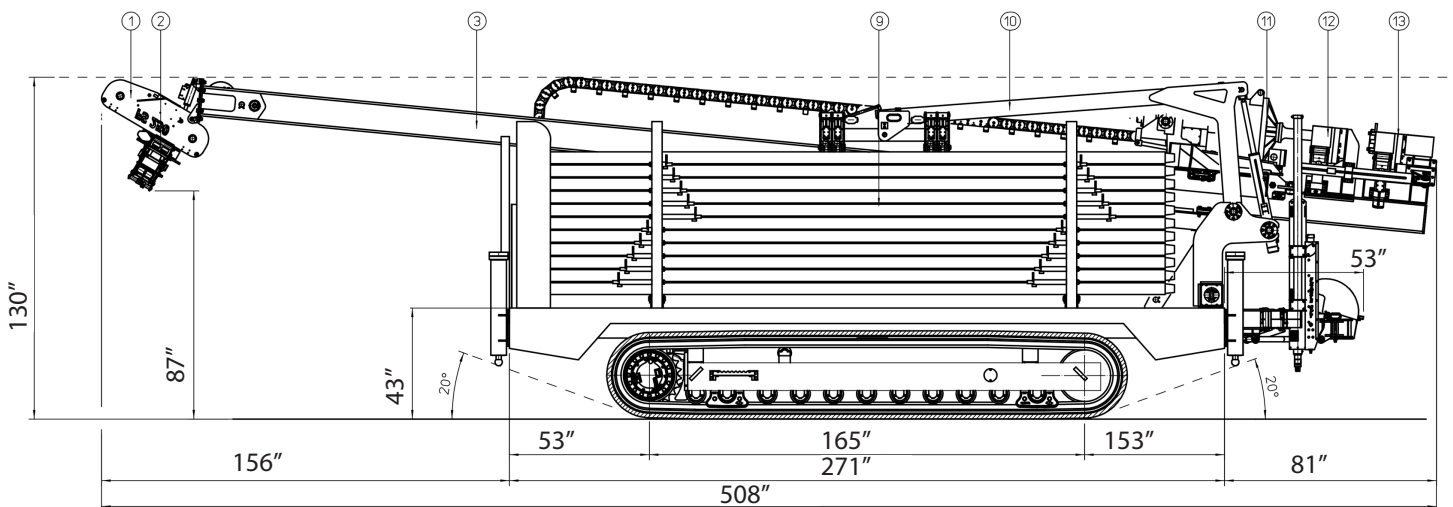

Feel the sonic vibe!

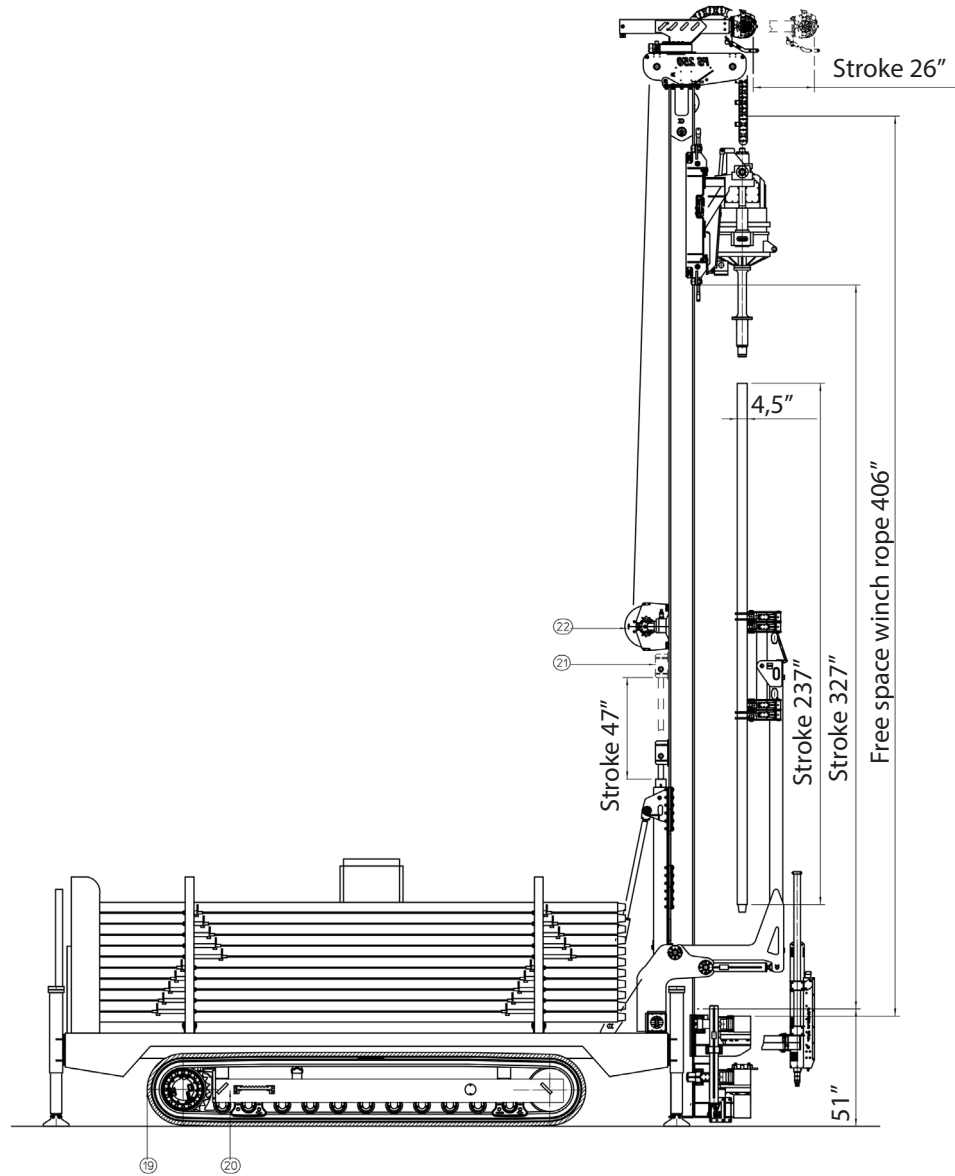

LRS FS250

LargeRotoSonic Crawler

LargeRotoSonic drill head:

- LargeSonic (50k) drill head including tilt frame
- 50.000 lbs of sonic output force
- 0-150 Hz Sonic frequency
- 0-140 RPM rotation
- 5250 ft-lb CW rotation torque @ 0-140 RPM
- 7000 ft-lb CW rotation torque @ 0-140 RPM
- 0-90 degr. tilt capacity

Rig

- Dimensions depending on options
- Height (when drilling) max. 100'00 mm / 32'11"
- CAT 6 cylinder water cooled diesel engine 216 kW / 355 HP
- Fuel tank 190 liter / 50 gallon
- Load sense hydraulic system
- Control panel on turning arm
- High pressure water pump 19 l/min @ 210 bar / 5 gpm @ 3045 PSI
- FMC Bean Mud 160 l/min @ 45 bar / 42 gpm @ 652 PSI
- Aluminum water tank 500 liter / 132 gallon
- Rubber tracks
- Radio remote for driving
- Working lights

Fully automated rod or casing handler

- Mechanical separators among different rod layers
- Casing or drill rod storage depends on diameter and length

Mast

- Stroke 5200 mm / 17' stroke
- Mast dump 1200 mm / 3' 11"
- Pull up 120 kN / 26977 lbf
- Pull down 80 kN / 17984 lbf
- Pull up & down speed 45 m/min / 147 ft/min
- Double hydraulic break out clamp 60 - 350 mm / 2-3/8" - 13-7/8"
 - Adjustable clamping force of 250 kN / 562002 lbf
 - Break out torque 78 kNm / 57530 ft-lbf
 - Hydraulic break out cylinder

Winch

- Wireline winch 2250 ft-lbf, speed 328' / min 328' cable

Options:

- SPT auto drop hammer with blow counter on control panel
- Casing lifter mounted on break out clamp 200 kN / 45000 lbs, stroke 300 mm / 12"
- Pneumatic separators among different rod layers
- Duplex mud pump 570 liter @ 45 bar / 150 gallon @ 652 PSI
- Steel tracks
- Swivel for liquid, foam or air; 35 bar/ 507 PSI
- Triple floatable clamp
- Rotatable jib with second winch

