

GS3

*Water Content, EC
and Temperature Sensors*



Operator's Manual

Version 0



Decagon Devices, Inc.

2365 NE Hopkins Court

Pullman WA 99163

www.decagon.com

soils@decagon.com

©2011 Decagon Devices, Inc.

All rights reserved

Contents

1. Introduction	1
Specifications	1
Contact Information	2
Warranty Information	2
Seller's Liability	3
2. About the GS3	4
3. Theory	5
Volumetric Water Content	5
Temperature	5
Electrical Conductivity	6
Converting Bulk EC to Pore EC	6
Pore Water vs. Solution EC	8
4. Calibration	10
Dielectric Permittivity	10
Calibration for Soilless Media	10
5. Connecting Sensors	12
Connecting to an Em50/Em50R logger	12
3.5mm Stereo Plug Wiring	13
Connecting to a Non-Decagon Logger	13

6. Communication	16
Serial Communication	16
SDI-12 Communication	17
Sensor Bus	18
Address	19
Power	19
Reading	20
Campbell Scientific Programs	21
7. Installing the Sensors	22
Orientation	22
Removing the sensors	23
Cleaning the Probes	23
8. Troubleshooting	24
Declaration of Conformity	25

1. Introduction

Thank you for choosing Decagon's GS3 Greenhouse Sensor for measuring water content, temperature, and EC. This manual is designed to help you understand the sensor's features and how to use this device successfully.

Specifications

Volumetric Water Content

Accuracy: ε_a : $\pm 1 \varepsilon_a$ (unitless) from 1-40 (soil range), $\pm 15\%$ from 40-80:

- Using a generic calibration: $\pm 0.03 \text{ m}^3/\text{m}^3$ ($\pm 3\%$ VWC) typical in mineral soils that have solution electrical conductivity $< 5 \text{ dS/m}$
- Using medium specific calibration, $\pm 0.01 - 0.02 \text{ m}^3/\text{m}^3$ ($\pm 1-2\%$ VWC) in any porous medium

Resolution: ε_a : $0.1 \varepsilon_a$ (unitless) from 1-20
 $< 0.75 \varepsilon_a$ (unitless) from 20-80

$0.002 \text{ m}^3/\text{m}^3$ (0.2% VWC) from 0 to 40% VWC

$0.001 \text{ m}^3/\text{m}^3$ (0.1% VWC) $> 40\%$ VWC

Range: Apparent dielectric permittivity (ε_a): 1 (air) to 80 (water)

Bulk Electrical Conductivity

Accuracy: $\pm 10\%$ from 0 to 10 dS/m, user calibration required above 10 dS/m

Resolution: 0.001 dS/m from 0 to 23 dS/m

GS3 Operator's Manual

1. Introduction

Range: 0 to 23 dS/m (bulk)

Temperature

Accuracy: ± 1 °C

Resolution: 0.1 °C

Range: -40-50 °C

General Specifications

Dimensions: 9.3 x 2.4 x 6.5 cm

Prong Length: 5.5 cm

Dielectric Measurement Frequency: 70 MHz

Measurement Time: 150 ms (milliseconds)

Power requirements: 3.6 - 15 VDC, 0.03 mA quiescent, 25 mA during 150 ms measurement

Output: Serial TTL, 3.6 Volt Levels or SDI-12

Operating Temperature: -40 to 50 °C

Connector types: 3.5 mm (stereo) plug or stripped & tinned lead wires (Pigtail)

Cable Length: 5m standard; custom cable length available upon request

Contact Information

If you need to contact Decagon:

- **Call us** at 800-755-2751 or (509) 332-2756
- **Fax us** at (509) 332-5158
- **E-mail us** at support@decagon.com.

Warranty Information

All Decagon products have a 30-day satisfaction guarantee and a one-year warranty.

Seller's Liability

Seller warrants new equipment of its own manufacture against defective workmanship and materials for a period of one year from date of receipt of equipment (the results of ordinary wear and tear, neglect, misuse, accident and excessive deterioration due to corrosion from any cause are not to be considered a defect); but Seller's liability for defective parts shall in no event exceed the furnishing of replacement parts F.O.B. the factory where originally manufactured. Material and equipment covered hereby which is not manufactured by Seller shall be covered only by the warranty of its manufacturer. Seller shall not be liable to Buyer for loss, damage or injuries to persons (including death), or to property or things of whatsoever kind (including, but not without limitation, loss of anticipated profits), occasioned by or arising out of the installation, operation, use, misuse, nonuse, repair, or replacement of said material and equipment, or out of the use of any method or process for which the same may be employed. The use of this equipment constitutes Buyer's acceptance of the terms set forth in this warranty. There are no understandings, representations, or warranties of any kind, express, implied, statutory or otherwise (including, but without limitation, the implied warranties of merchantability and fitness for a particular purpose), not expressly set forth herein.

2. About the GS3

The GS3 Greenhouse Sensor is designed to measure the water content, electrical conductivity and temperature of many types of growing media. The GS3 was developed to work primarily in greenhouse applications where the slim, stainless steel needles could be inserted easily into many types of substrates, but it can work in many other applications as well.

3. Theory

Volumetric Water Content

The GS3 sensor uses an electromagnetic field to measure the dielectric permittivity of the surrounding medium. The sensor supplies a 70 MHz oscillating wave to the sensor prongs that charges according to the dielectric of the material. The stored charge is proportional to substrate dielectric and substrate volumetric water content. The GS3 microprocessor measures the charge and outputs a value of dielectric permittivity from the sensor. The dielectric value is then converted to substrate water content by a calibration equation specific to the media you are working in.

Temperature

The GS3 uses a small thermistor to take temperature readings. It is located underneath the sensor overmold, next to one of the prongs so it remains in thermal equilibrium with the medium, and will read the temperature of the prong surface. The GS3 will output temperature in °C unless otherwise stated in your preferences file in either the DataTrac 3 or ECH₂O Utility programs.

It is important to note that even though the sensor head is white, if it is in direct sunshine, the temperature measurement may read high. Exposure of the sensor head to direct UV radiation may also degrade the vinyl surface and causing

it to discolor. Use caution when installing the sensor with the overmold in the sun.

Electrical Conductivity

Electrical conductivity (EC) is the ability of a substance to conduct electricity and can be used to infer the amount of polar molecules that are in solution. EC is measured by applying an alternating electrical current to two electrodes, and measuring the resistance between them. Conductivity (referred to as “bulk electrical conductivity”) is derived by multiplying the inverse of the resistance (conductance) by the cell constant (the ratio of the distance between the electrodes to their area). The bulk EC measurement is calibrated at the factory to be accurate within $\pm 10\%$ from 0 to 10 dS/m. This range is adequate for most greenhouse and nursery applications. However, some special applications in highly saline substrates may require measurements with bulk EC greater than the specified range. The GS3 will measure up to 23 dS/m bulk EC, but user calibration is required above 10 dS/m. Additionally, EC measurements above 10 dS/m are very sensitive to contamination of the electrodes by skin oils, etc. Be sure to read the sensor cleaning section at the end of the manual if you plan to measure the EC of salty soils.

Converting Bulk EC to Pore EC

For many applications, it is advantageous to know the electrical conductivity of the solution contained in the soil pores (σ_p), which is a good indicator of the solute concentration in the soil. Traditionally, σ_p has been obtained by extracting pore water from the soil and measuring σ_p directly. As one

would expect, this is a time consuming and labor intensive process.

The GS3 measures the electrical conductivity of the bulk soil surrounding the sensors (σ_b). A considerable amount of research has been conducted to determine the relationship between σ_b and σ_p . Work by Hilhorst (2000), has taken advantage of the linear relationship between the soil bulk dielectric permittivity (ϵ_b) and σ_b to allow accurate conversion from σ_b to σ_p if the ϵ_b is known. The GS3 measures ϵ_b and σ_b nearly simultaneously in the same soil volume. It is therefore well suited to this method.

The pore water conductivity can be determined from (see Hilhorst, 2000 for derivation):

$$\sigma_p = \frac{\epsilon_p \sigma_b}{\epsilon_b - \epsilon_{\sigma_b=0}} \quad (1)$$

where σ_p is the pore water electrical conductivity (dS/m); ϵ_p is the real portion of the dielectric permittivity of the soil pore water (unitless); σ_b is the bulk electrical conductivity, (dS/m), which is measured directly by the GS3; ϵ_b is the real portion of the dielectric permittivity of the bulk soil (unitless); $\epsilon_{\sigma_b=0}$ is the real portion of the dielectric permittivity of the soil when bulk electrical conductivity is 0 (unitless).

ϵ_p can be calculated from soil temperature using:

$$\epsilon_p = 80.3 - 0.37 * (T_{soil} - 20) \quad (2)$$

where T_{soil} is the soil temperature (C) measured by the GS3.

Finally, $\epsilon_{\sigma_b=0}$ is an offset term loosely representing the dielectric permittivity of the dry soil. Hilhorst (2000) recom-

mended that $\epsilon_{\sigma_b=0} = 4.1$ be used as a generic offset. However, our research in several agricultural soils, organic, and inorganic growth media indicates that $\epsilon_{\sigma_b=0} = 6$ results in more accurate determinations of σ_p . Hilhorst (2000) offers a simple and easy method for determining for individual soil types, which will improve the accuracy of the calculation of σ_p in most cases.

Our testing indicates that the above method for calculating σ_p results in good accuracy ($\pm 20\%$) in moist soils and other growth media. In dry soils where VWC is less than about $0.10 \text{ m}^3/\text{m}^3$, the denominator of equation 1 becomes very small, leading to large potential errors. We recommend that σ_p not be calculated in soils with $\text{VWC} < 0.10 \text{ m}^3/\text{m}^3$ using this method.

Pore Water vs. Solution EC

As noted in the previous section, pore water electrical conductivity can be calculated from bulk EC using the sensor-measured dielectric permittivity of the medium. However, pore water EC is not the same as solution EC. Pore water EC is the electrical conductivity of the water in the pore space of the soil. One could measure this directly if the soil was squeezed under high pressure to force water out of the soil matrix and that water was collected and tested for EC. Solution EC is the electrical conductivity of pore water removed from a saturated paste. In this case, the soil is wetted with distilled water until the soil saturates, then the soil is placed on filter paper in a vacuum funnel and suction is applied. An electrical conductivity measurement on the water removed from the sample will give the solution electrical conductivity. Theoretically, the two are related by the

bulk density. An example calculation will illustrate this relationship: A soil is at $0.1 \text{ m}^3/\text{m}^3$ VWC, has a pore water EC of 0.7 dS/m , and a bulk density of 1.5 Mg/m^3 . We can calculate the solution EC as follows.

$$\phi = 1 - \frac{\rho_b}{\rho_s} = 1 - \frac{1.5}{2.65} = 0.43$$

$$\text{Solution EC} = \frac{\sigma_p \theta + \sigma_d (\phi - \theta)}{\phi} = \frac{0.7(0.1) + 0}{0.43} = 0.162 \text{ dS/m}$$

In this example, ϕ is the porosity, ρ_b is bulk density, ρ_s is density of the minerals (assumed to be 2.65 Mg/m^3), subscript d is distilled water, and θ is volumetric water content. We assume that the EC of the distilled water is 0 dS/m . In practice, solution EC calculated from this method and solution EC taken from a laboratory soil test may not agree well because wetting soil to a saturated paste is very imprecise.

Reference

Hilhorst, M.A. 2000. A pore water conductivity sensor. Soil Science Society of America Journal 64:6 1922-1925

4. Calibration

Dielectric Permittivity

In some specific cases, a calibration that gives dielectric permittivity (combined real and imaginary) for the GS3 is useful. The dielectric of the medium, ϵ_a is the standard output of the GS3 before a calibration is applied. This output is calibrated at the factory.

Calibration for Soilless Media

The GS3 has been calibrated in media types including potting soil, perlite and peat. The goal of these calibrations is to create a generic calibration equation that will work in all types of each substrate, with an accuracy of better than $\pm 5\%$ volumetric water content (VWC). If you need more accuracy, you can perform a media-specific calibration to get the accuracy down to ± 1 to 2%. It is interesting to note that the main difference between the calibrations is caused by the high air volume in the organic soils that lowers the starting (dry media) dielectric of the sensor. For more information on how to calibrate your probes, please see <http://www.decagon.com/support>. Decagon also has a calibration service, where we will perform the calibration for a standard fee. Contact Decagon for more information about this calibration service.

The calibration for several potting soils, perlite, and peat moss at salinities ranging from 0 to > 4 dS/m is given:

$$\text{VWC (m}^3/\text{m}^3) = 0.118\sqrt{\epsilon_a} - 0.117$$

The calibration for mineral soils ranging from 0 to > 5 dS/m is given:

$$\text{VWC (m}^3/\text{m}^3) = 5.89 \times 10^{-6} \epsilon^3 - 7.62 \times 10^{-4} \epsilon^2 + 3.67 \times 10^{-2} \epsilon - 7.53 \times 10^{-2}$$

5. Connecting Sensors

The GS3 sensor was designed to work most efficiently with Decagon's Em50, Em50R, Em50G or our ProCheck handheld reader. They can also be used with other data loggers, such as those from Campbell Scientific, Inc. The GS3 requires an excitation voltage in the range of 3.6-15 V and outputs at 3.6 V levels. Although capable of communicating in TTL serial, the GS3 can also be interrogated using the SDI-12 protocol with the sensor continuously powered (see section 6).

Connecting to an Em50/Em50R logger

The GS3 has been designed to work specifically with the Em50 datalogger. To download data to your computer, you will need to install ECH₂O Utility, DataTrac 3 or a terminal-port program on your computer. The following software support the GS3 sensor:

Em50 Firmware version 2.05
ECH₂O Utility 1.62 or greater
DataTrac 3.3 or greater

Please check your software version to ensure it will support the GS3. To update your software to the latest versions, please visit Decagon's support site (<http://www.decagon.com/support/>).

To use the GS3 with your Em50 data logger, simply plug the stereo plug into one of the five ports on the data logger and use either ECH₂O Utility, or DataTrac 3 software (see

respective manuals) to configure that port for the GS3 and set the measurement interval.

3.5mm Stereo Plug Wiring

GS3 sensors used with Decagon loggers come with a 3.5mm "stereo plug" connector. The stereo plug allows for rapid connection directly to Decagon's Em50 and Em50R dataloggers and to the hand-held ProCheck readers. Below is a diagram showing the wiring configuration for this connector.

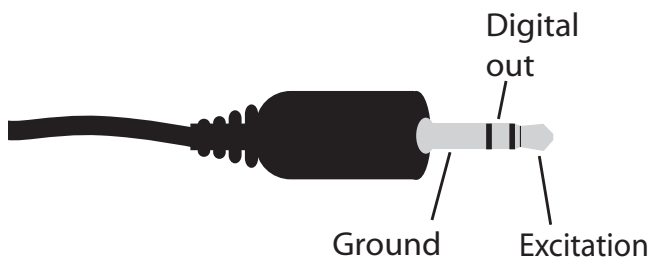

Connecting to a Non-Decagon Logger

GS3 sensors may be purchased for use with non-Decagon data loggers. These sensors typically come pre-configured with stripped and tinned (pigtail) lead wires for use with screw terminals. Refer to your distinct logger manual for details on wiring. Our integrator's guide gives detailed instructions on connecting the GS3 sensor to non-Decagon loggers. Please visit www.decagon.com/support for the complete integrator's guide.

GS3 Operator's Manual

5. Connecting Sensors

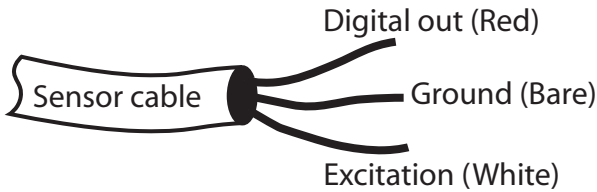

GS3 sensors with the stripped and tinned cable option can be made with custom cable lengths (up to 1000 ft) on a per-foot fee basis. This option gets around the need for splicing wire (a possible failure point). Connect the wires to the data logger as shown, with the supply wire (white) connected to the excitation, the digital out wire (red) to a digital input, the bare ground wire to ground as seen below.

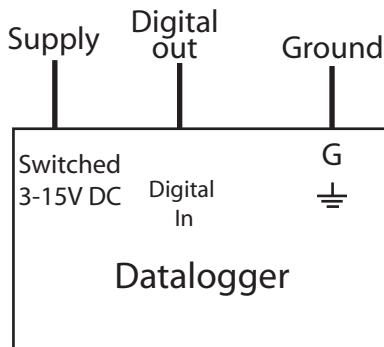

NOTE: The acceptable range of excitation voltages is from 3.6-15 VDC. If you wish to read the GS3 with the Campbell Scientific Data Loggers, you will need to power the sensors off of the 12V port (switched if you use TTL serial).

If your GS3 is equipped with the standard 3.5mm plug, and you wish to connect it to a non-Decagon datalogger, you have two options. First, you can clip off the plug on the sensor cable, strip and tin the wires, and wire it directly into the datalogger. This has the advantage of creating a direct connection with no chance of the sensor becoming un-plugged; however, it then cannot be easily used in the future with a Decagon readout unit or datalogger. The other option is to obtain an adapter cable from Decagon. The 3-wire sensor adapter cable has a connector for the sensor jack on one end, and three wires on the other end for connection to a datalogger (this type of wire is often referred to as a "pigtail adapter"). Both the stripped and tinned adapter cable wires have the same termination as seen above; the white wire is excitation, red is output, and the bare wire is ground.

NOTE: Be extra carefull to secure your stereo to pigtail adapter connections to ensure that sensors don't become disconnected during use.

6. Communication

The GS3 sensor can communicate using two different methods, Serial (TTL) and SDI-12. In this chapter we will briefly discuss the specifics of each of these communication methods. Please visit www.decagon.com/support for the complete integrator's guide, which gives more detailed explanations and instructions.

Serial Communication

The GS3 will communicate in both serial and SDI-12. In some applications where non-Decagon dataloggers are used, SDI-12 will be the best choice.

When excitation voltage is applied, the GS3 makes a measurement. Within about 50 ms of excitation three measurement values are transmitted to the data logger as a serial stream of ASCII characters. The serial out is 1200 baud asynchronous with 8 data bits, no parity, and one stop bit. The voltage levels are 0-3.6V and the logic levels are TTL (active low). The power must be removed and reapplied for a new set of values to be transmitted.

The ASCII stream contains 3 numbers separated by spaces. The stream is terminated with the carriage return character. The first number is the dielectric permittivity (ϵ), the second number is temperature in $^{\circ}\text{C}$, and the third is the electrical conductivity in $\mu\text{S}/\text{cm}$.

SDI-12 Communication

The GS3 sensor can also communicate using the SDI-12 protocol, a three-wire interface where all sensors are powered (white wire), grounded (bare wire), and communicate (red wire) on shared wires (for more info, go to www.sdi-12.org). There are some positive and negative elements of this protocol. On the positive side, up to 62 sensors can be connected to the same 12 V supply and communication port on the datalogger. This simplifies wiring because no multiplexer is necessary. On the negative side, one sensor problem can bring down the entire array (through a short circuit, etc.). To avoid this problem, we recommend the user make an independent junction box with wire harnesses where all sensor wires are connected to wire lugs so sensors can be disconnected if a problem arises. A single three-wire bundle can be run from the junction box to the datalogger.

The SDI-12 protocol requires that all sensors have a unique address. GS3 sensors come from the factory with an SDI-12 address of 0. To add more than one SDI-12 sensor to a system, the sensor address must change. Address options include {0...9, A...Z, a...z}. There are two ways to set the SDI-12 sensor address. The best and easiest is to use Decagon's ProCheck (if the option is not available on your ProCheck, please upgrade to the latest version of firmware). SDI-12 addressing can be accessed in the "CONFIG" menu by selecting "SDI-12 Address" and pressing "ENTER". To change the SDI-12 address, press the up and down arrows until you see the desired address and push "Enter". SDI-12 communication allows many parameters to be communicated at once, so you can also see things like the sensor

model, SDI-12 version, etc. SDI-12 communication is also supported in Campbell Scientific dataloggers like the CR10X, CR1000, CR3000, etc. Direct SDI-12 communication is supported in the "Terminal Emulator" mode under the "Tools" menu on the "Connect" screen. Detailed information on setting the address using CSI dataloggers can be found on our website at <http://www.decagon.com/support/downloads/>.

The sensor can be powered using any voltage from 3.6 to 15 VDC, but 12 V is optimal. The SDI-12 protocol allows the sensors to be continuously powered, and we recommended that the power (white wire) be connected to a continuous 12 VDC source. However, the sensor can also be used with a switched 12 V source. This can help reduce power use (although the GS3 sensors use very little power, 0.03 mA quiescent) and will allow the sensor array to be reset if a problem arises.

Reading the GS3 sensor in SDI-12 mode using a CSI datalogger requires a function call. An example program from Edlog and CRBasic can be found in the software section of <http://www.decagon.com/support/>. The dielectric permittivity (ϵ) is the first number output by the sensor, the second number is temperature in $^{\circ}\text{C}$, and the third is the electrical conductivity in $\mu\text{S}/\text{cm}$.

Sensor Bus

The SDI-12 protocol allows up to 62 sensors to be wired together at once. This requires that all sensor supply (white) wires are connected together, all digital out (red) wires are connected together, and all ground (bare) wires are connected together. Sharing these wires is often called a "bus",

which means that communication runs along the common digital out wire and each sensor, as well as the host, will "hear" all communication. Communication is therefore addressed specifically to each sensor.

For example, when a reading is needed, the host will first address the specific sensor that needs to make a measurement, tell it to make a measurement, then tell it to send its answer back to the host. Please note that, because the supply wire is in common with all sensors, a problem with a single sensor can be catastrophic to the bus system. A short circuit on one sensor (from shovel-blight, for example) will bring the entire bus down until that sensor is removed from the bus.

Address

SDI-12 sensors communicate on a three-wire bus. To avoid complete chaos, each sensor is given a unique address so the host can communicate to each sensor directly. This address can be any number from 0 to 9, any letter from capital A to Z, and any letter from small a to z. Every sensor **MUST** have a unique address on the system, otherwise two or more sensors will respond at once to a host request, creating confusion and data loss. Sensors are shipped from the factory with an address of "0". Thus, if you plan on using SDI-12 with multiple sensors on a single bus, you will have to start by addressing your sensors individually as noted in the section above.

Power

The GS3 is an extremely low power sensor; when continuously powered, but not making a measurement or communi-

cating, it uses 30 μ A. Therefore, we recommend that it be powered continuously off a 12V port on a datalogger. It is also possible to switch the power, or use other excitation levels besides 12V, as long as it is between 3.6 and 15 V. No difference in sensor readings will occur.

Reading

One of the advantages of the SDI-12 protocol is the number of possible queries that can be made to the sensor. From the standard sensor readings (dielectric, temperature, and EC) to calibration coefficients, several parameters can be stored in the sensor and read back. For typical use, all that is needed is a simple output of dielectric, temperature, and EC. The sequence to gather those values is quite simple (Address the sensor | tell it what you'd like it to do | end with a "!"). For example:

0R0! (Address sensor "0" | take an instantaneous reading "R0" | end the statement "!")

Most dataloggers will run this sequence without any user input, but occasionally it is necessary to interrogate the sensor directly. A full list of the SDI-12 commands implemented in the GS3 is available by contacting Decagon.

Additional examples of SDI-12 programs can be found at our software section online at <http://www.decagon.com/support/downloads>.

Campbell Scientific Programs

The GS3 is a SDI-12 compatible sensor. This makes programming for the sensor in CRBasic or Edlog straightforward. Simply choose the SDI-12 Recorder command and input the necessary parameters. As mentioned earlier, the sensor outputs three values, so be sure to define your array size as 3 in CRBasic (i.e. Public GS3Out(3)) or leave room for two more parameters after your "Loc" call in Edlog. Example programs can be found at www.decagon.com/support.

7. Installing the Sensors

The GS3 sensor can be inserted into soilless substrates in a variety of ways; however, the orientation of the sensor will possibly affect the sensor accuracy. In addition, high spatial variability in soilless substrates will drastically affect the difference between sensor readings from one location to another.

Orientation

The goal of installing a sensor into a substrate is to measure those parameters important to plant growth while not changing them. The GS3 can be installed in many different orientations, depending on your needs. However, common sense should be used. For example, installing the sensor in the top of a pot that is being irrigated by micro-sprinkler may cause water to drip around the sensor head, leaving a dry patch of soil immediately below. A better option would be to insert the sensor into the side of the root mass with the needles horizontal, aligned in a vertical row.

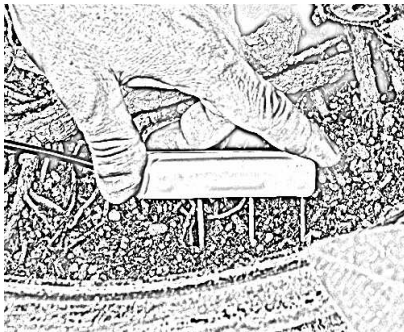

This will allow water to flow freely through the pot and measurements to be made directly around the roots. Still, when irrigation water is not applied from the surface, it may be entirely appropriate to install the sensor on top of the substrate. However, please keep in mind that the sensor only measures the VWC in its sphere of influence.

Sensors can either be inserted into the top of the plant pot or into the side of the root ball. Insertion into the side of the root ball may be the best option, as it will give the best indication of the water available to the plant.

Removing the sensors

The GS3 is easily removed from substrates. The stainless steel needles slip easily in and out of all types of growing media. Still, we recommend the sensors never be pulled out by their cables, as this can put immense strain on the wires inside. If the sensor is buried, carefully dig down to the sensor, taking care not to damage the cable with your digging implement. After removing the media around the head, simply grab onto the sensor and remove it

Cleaning the Probes

1. Scrub the prongs vigorously with a Scotch Brite abrasive pad. We recommend rubbing each pin a minimum of 5 times, with medium to hard pressure.
2. Rinse the sensor and prongs thoroughly with tap or DI water.

Note: Be sure not to touch the prongs with an un-gloved hand or contact them with any source of oil or other non-conducting residue.

8. Troubleshooting

Problem #1: Sensor not responding:

- Check power to the sensor
- Check sensor cable and 3.5 mm plug integrity
- Check datalogger wiring to ensure White - 12 V supply, Red - Digital out, Bare - Ground.

Problem #2: Sensor reading too low:

- Check for air gaps around sensor needles. These could be produced below the surface of the substrate when the needle contacts a large piece of material and pushes them out of the way.
- Ensure the calibration equation you are using is appropriate for your media type. There are significant differences between substrate calibrations so be sure to use the one specific to your substrate.

Problem #3: Sensor reading are too high:

- Check to make sure that the media was not packed excessively during sensor installation. Higher density can cause sensor reading to be elevated.
- Ensure the calibration equation you are using is appropriate for your media type. There are significant differences between substrate calibrations so be sure to use the one specific to your substrate.

Declaration of Conformity

Application of Council Directive:89/336/EE6

**Standards to Which Conformity
is Declared:** EN61326 : 1998
EN51022 : 1998

Manufacturer's Name: Decagon Devices, Inc.
2365 NE Hopkins Court
Pullman, WA 99163 USA

Type of Equipment: Dielectric soil
moisture sensor

Model Number: GS3

Year of First Manufacture: 2011

This is to certify that the GW3 greenhouse sensor, manufactured by Decagon Devices, Inc., a corporation based in Pullman, Washington, USA meet or exceed the standards for CE compliance as per the Council Directives noted above. All instruments are built at the factory at Decagon and pertinent testing documentation is freely available for verification.

GS3 Operator's Manual
Declaration of Conformity

Index

B

Bulk EC 6

C

Calibration

soilless media 10

Communication 16

SDI-12 17

Serial (RS232) 16

Contact information 2

Converting bulk EC to pore EC 6

CSI loggers

using GS3 sensors with 21

D

Declaration of Conformity 25

Dielectric permittivity 10

E

Electrical conductivity (EC) 6

H

How the GS3 works

electrical conductivity 6

temperature 5

volumetric water content 5

I

Installation

orientation 22

removing the probe 23

L

Logger

Non Decagon 13

P

Pore water EC 6

Potting Soil Calibration 11

Power requirements 2

R

Rockwool Calibration 11

S

Seller's liability 3

Sensor accuracy 1

Sensor range 1

Sensor resolution 1

Solution EC 8

Specifications 1

T

Troubleshooting 24

V

Volumetric water content 5

W

Warranty information 2

Wiring

pigtail 14

stereo plug 13