

OPERATING INSTRUCTIONS

04.01/04.02 CORE SAMPLERS



Contents:

| | |
|--|----|
| About the instructions | 2 |
| Introduction | 2 |
| 1. Description | 2 |
| 1.1 General information | 2 |
| 1.2 Single gouge auger set for more or less soft soils | 3 |
| 1.3 Single gouge auger for hard soils | 3 |
| 1.4 Single gouge auger set for very hard soils | 3 |
| 1.5 Bi-partite gouge auger set for more or less soft soils | 4 |
| 1.6 Bi-partite gouge auger set for hard soils | 5 |
| 2. Technical specifications | 6 |
| 3. Safety instructions | 6 |
| 4. Preparing for use | 6 |
| 5. The use of gouge augers | 7 |
| 5.1 Single gouge auger set for more or less soft soils | 7 |
| 5.2 Single gouge auger for hard soils | 8 |
| 5.3 Single gouge auger set for very hard soils | 9 |
| 5.4 Bi-partite gouge auger sets | 9 |
| 6. Applications | 11 |
| 7. Troubleshooting | 12 |
| 8. Maintenance | 13 |

On these operating instructions



If the text follows a mark (as shown on the left), this means that an important instruction follows.



If the text follows a mark (as shown on the left), this means that an important warning follows relating to danger to the user or damage to the apparatus.

Introduction

In soil research to a depth of 5 to 10 meters hand auger equipment may be used. Gouge augers are often used in cohesive soils and may easily produce an overview of profiles with hardly disturbed samples. Single, non-extendable gouge augers, and bi-partite, extendable gouge augers are available. These instructions deal with various sets of types of gouge augers.

Upon erosion of rock soils are formed and transported by natural processes to be deposited elsewhere. Soils consist of minerals, organic material and cavities filled with air and/or water. The minerals may vary in size of clay and loam (<63 mm) and sand (63 mm – 2 mm), to gravel (2 - 63 mm) and stones (>63 mm).

Soil in its natural position may consist of various soil types (stratified or heterogeneous soil). Differences in texture or soil-forming processes lead to stratification. Soils type will vary from clay, loam, sand to stony soil, depending on its loam and sand content. Peaty soil mostly consists of organic material. Cohesive soils, for instance, are wet clay, loam and peaty soil. Sand and stony soils are moderately cohesive.

Gouge auger sets are often used in profile research for surveying purposes, soil assessment and rootage surveys. Standard gouge augers are suitable for use in soft soils such as peat, clay and sandy or disturbed soils. Heavy-duty gouge augers have been developed for hard soils such as loam and stony soils. They are driven into the soils using a hammer. The single type sets are suitable for topsoil research. The bi-partite auger sets are used in soil research to a depth of 5 m, depending on soil structure and soil composition.

1. Description

1.1 General information

All gouge augers have similar characteristics:

- The auger body is half-cylindrical with parallel running cutting edges. The standard effective auger body measures 50 or 100 cm. The diameter may vary, but 30 mm is standard.
- The gouge augers are made from high-quality steel, which under normal conditions will not permit torsion of the auger body.
- The gouge auger body has a 10-cm calibration.

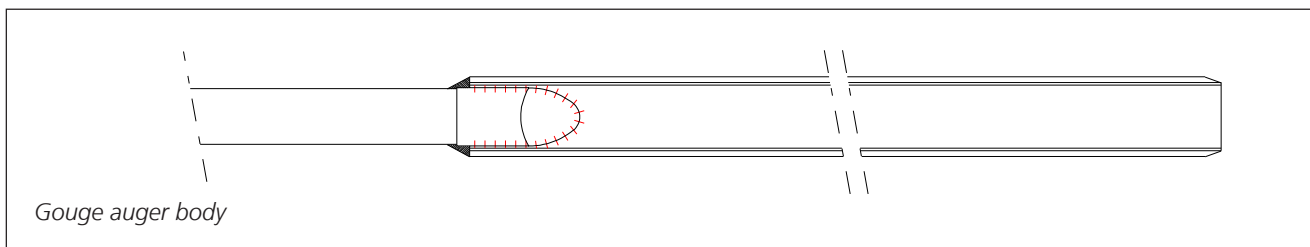

- Single gouge augers are not extendable; auger body and grip are integrated, rendering stability and easy use in topsoil research.
- The bi-partite gouge auger is extendable; its parts (upper part, and bottom part with auger body, and extensions) can be coupled using a bayonet or a conical thread connection.

1.2 Single gouge auger set for more or less soft soils

The single gouge auger set for more or less soft soils (left-hand figure) consists of two regular single gouge augers (1, 2), a bent spatula (3) and a carrying bag (4). The set is suitable for use in softer soils such as peat, clay and sandy or disturbed soils.

Both augers measure 110 cm; their operational depths are 50 (1) and 100 cm (2) respectively. The upper part has rubber grips.

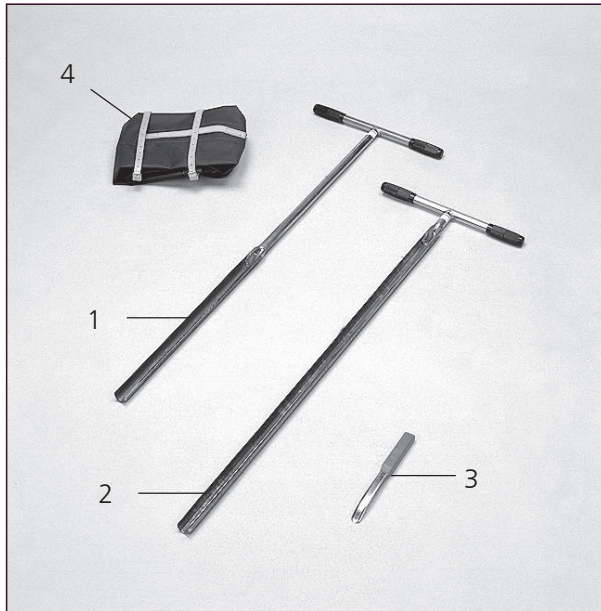

Single gouge auger set for more or less soft soils (left)

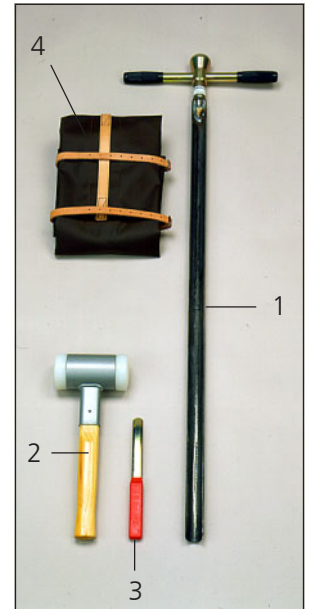

Single gouge auger set for hard soils (right)

1.3 Single gouge auger set for hard soils

The single gouge auger set for hard soils (right-hand figure) consists of a gouge auger with a heavy-duty auger body (1), an impact-absorbing steel hammer (2), a bent spatula (3) and a carrying bag (4). The set is suitable for use in harder soils such as dry soils or soils containing debris.

The auger's body has an operational depth of 100 cm and has a beating head welded onto it. The upper part has rubber grips.

The steel hammer is impact-absorbing; its head contains lead bullets flowing in the direction of the stroke upon impact. Its nylon cups prevent damage to the gouge auger.

1.4 Single gouge auger set for very hard soils

The single gouge auger set for very hard soils consists of a gouge auger, Purckhauer type, a gouge auger pulling set with hammer, a bent spatula and a carrying bag. The set is suitable for use in very hard soils such as stiff loam and soils containing debris.

The Purckhauer gouge auger's operational depth is 100 cm and it has an 18-mm inside diameter (see left figure on page 4). The outside diameter varies from 25.5 mm at the bottom end to 30 mm at the top end. Its conical shape causes the gouge auger not to have too much frictional resistance of the soil. The top end has an opening for insertion of either the grip or the lever. The grip (2) has two telescoping parts. The tip of one of the halves is slanted and can be used to remove the soil sample.

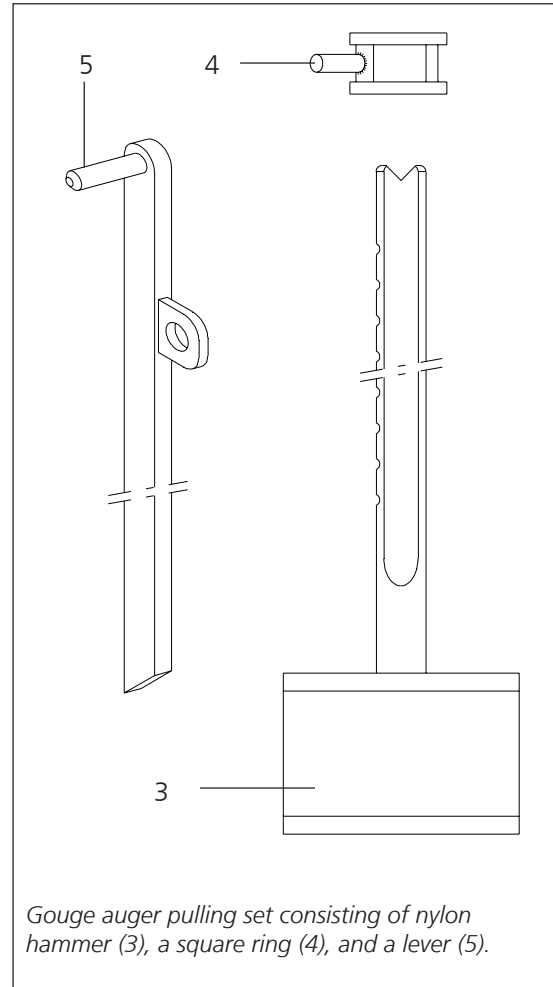
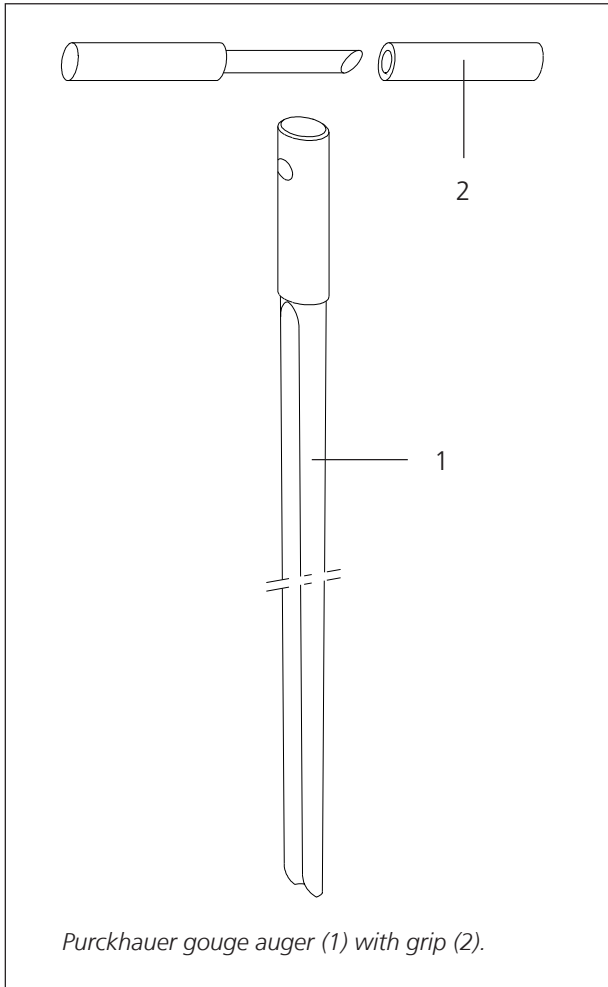

The solid nylon hammer (3) is not impact-absorbing, its handle has indentations at fixed distances and it can be used to:

- pound the Purckhauer gouge auger.
- withdraw the auger with the lever.

The gouge auger pulling set consists of a lever (5), a square ring (4) and a nylon hammer (3). The lever is a metal bar with an eye and a pin. One end of the bar is slanted to allow removal of the sample.

The square ring has a pin welded onto it at a 45° angle. The ring is slid over the hammer handle and caught in an indentation, the eye on the lever is fitted over the pin and the lever is now in position to withdraw the gouge auger (see paragraph 5.3).

1.5 Bi-partite gouge auger for more or less soft soils

The bi-partite gouge augers for more or less soft soils both consist of six bottom parts with various auger bodies, an upper part with a grip, extension rods, Edelman auger combination type, a push/pull handle and various accessories. A set of bayonet connections (see picture, page 1) is available, as well as one with conical thread connections. Both sets are suitable for softer soils such as peat, clay, and sandy or disturbed soils.

Auger bodies are available with either a 50-cm or a 100-cm operational depth, each with three different diameters: 20, 30 and 60 mm. The choice of type of auger depends on the type of soil, and on its use (see 6. Applications).

The Edelman auger combination type.

The Edelman auger body is conical in shape and consists of two blades (1) joined in a bit (2). The top of the blades is welded to a bracket (3), which is connected to the auger rod (4) (see figure). The blades are vaulted and when entering the soil the sample is dug up and evenly guided into the inside of the auger body. The vaulting of the blades not only promotes digging up but also ensures a firm grip of the sample while permitting easy emptying of the auger body.

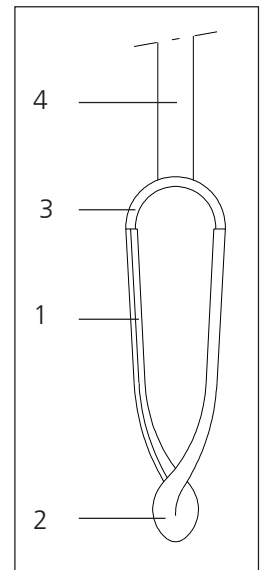

The Edelman combination type auger's diameter (measured diagonally between the blades at the broadest part of the auger body) measures 7 cm, the blades measure 35 mm in width. This permits a good hold of moderately cohesive soils, while cohesive soils can easily be removed.

Upper part, extension rods and connections.

The upper part measures 60 cm and has a detachable, synthetic grip. The extension rods measure 1 m. A total length of 5 m can be achieved by linking the extension rods.

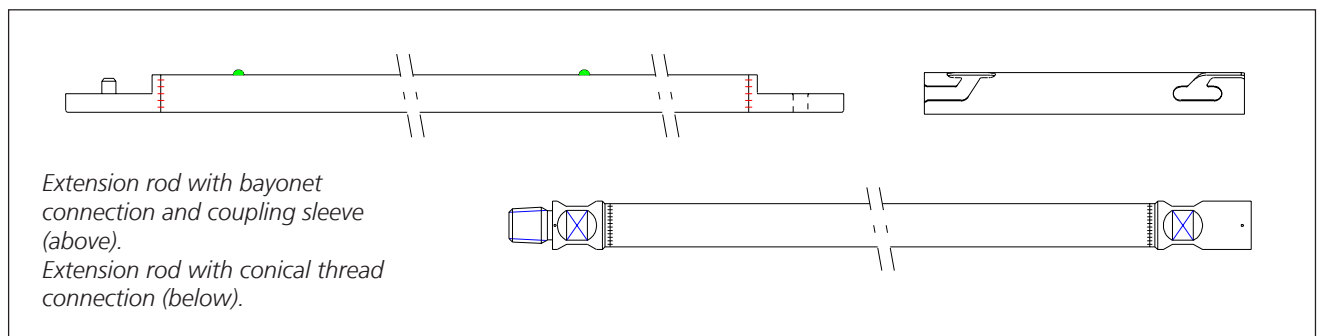

The tail ends of the extension rods are half-cylindrical and are fitted with either an eye or a pin. The eye and the pin lock into each other and are secured by a coupling sleeve. The extension rods with conical thread connections can be attached using a spanner.

The Push/Pull Handle.

The push/pull handle has two parts that can be fitted around a rod. Once pressure is exercised on the two bars of the handle its construction ensures a firm hold of the rod.

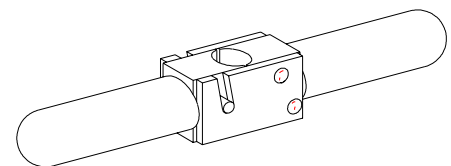

1.6 Bi-partite gouge auger set for hard soils

The bi-partite gouge auger set for harder soils consists of an upper part with beating head, a gouge auger with heavy-duty auger body, a steel hammer, an Edelman combination type auger, extension rods and various accessories. The parts in this set have conical thread connections. The set is suitable for use in hard soils such as dry soils or soils containing debris.

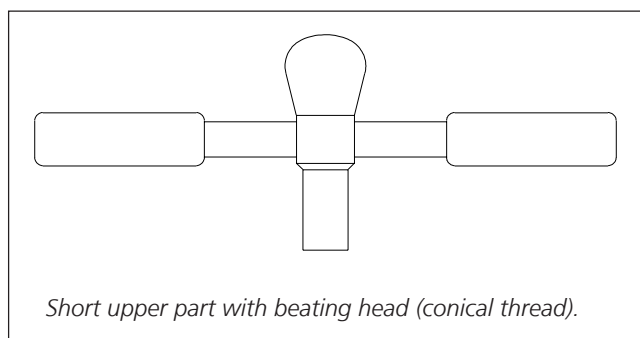

The gouge auger's operational depth measures 100 cm and has a 30-mm diameter (compare the single gouge auger for hard soils in paragraph 1.3).

The upper part with beating head measures 10 cm to ensure a proper operating position and stability.

2. Technical specifications

The table below lists the dimensions of various augers. The Edelman combination type auger's diameter is measured diagonally between the blades at the broadest part of the auger body!

| Gouge auger set | Auger type | Operational depth (cm) | Diameter (mm) |
|-------------------------|--|------------------------|------------------------------------|
| Single, soft soils | Standard gouge auger | 50, 100 | 30 |
| Single, hard soils | Heavy-duty gouge auger with beating head | 100 | 30 |
| Single, very hard soils | Purckhauer gouge auger | 100 | Outer: 25.5 – 30 Inner: 18 |
| Bi-partite, soft soils | Standard gouge auger Edelman auger | 50, 100 | 20, 30, 60 70 (blade width: 35) |
| Bi-partite, hard soils | Heavy duty gouge auger Edelman auger | 100 | 30 70 (blade width: 35) |

The auger bodies are made from iron-manganese steel (not stainless, non-toxic). All auger bodies are unpainted for the purpose of environmental research.

3. Safety Instructions



Hold the coupling sleeve of bayonet connections in the middle, this will prevent you from catching the skin of your hands between the parts while (dis)connecting them.



To withdraw the auger keep your back straight and your knees bent to prevent injuries.



Empty the gouge auger with a spatula. Make sure not to touch the cutting edges; they are very sharp. Inappropriate use may cause you to cut your hands.



Fill the borehole with soil or special bentonite plugs after augering. This will prevent humans or animals to trip into the hole and incur injuries. In addition, it will allow impermeable soil layers to recover.



Be cautious during a thunderstorm. Lightning strokes often occur in the open field, in particular when holding a metal auger.



Do not force, or pound on, the auger. Pounding may cause serious damage, such as cracks or snapped joints. Forcing may distort the auger body.



When using heavy-duty gouge augers, always utilise the impact-absorbing steel hammer if force is necessary. This is safer and will prevent damage to the auger. Avoid using standard metal hammers. This may cause damage to the auger and a bouncing hammer may lead to injuries.



While augering, hold the auger by its synthetic handle. It is fully insulated should you hit an electricity cable.



Augers over 4 m. should be handled in parts. This will prevent damage to the rods and reduce the risk of being hit by augers tipping over. This applies to inserting and hoisting the auger.

4. Preparing for use

Single auger sets:

Depending on the type of soil select an appropriate gouge auger (see 6. Applications).

Bi-partite auger sets:

1. Bayonets: Upon first use, detach the coupling sleeves from the extension rods and the upper part.
2. Screw the handle into the upper part.
3. Select an appropriate auger, depending on the type of soil (see 6. Applications).
4. Link the bottom part with auger body to the upper part. Use a spanner to connect the parts with a conical thread. For bayonet connections (see figure):

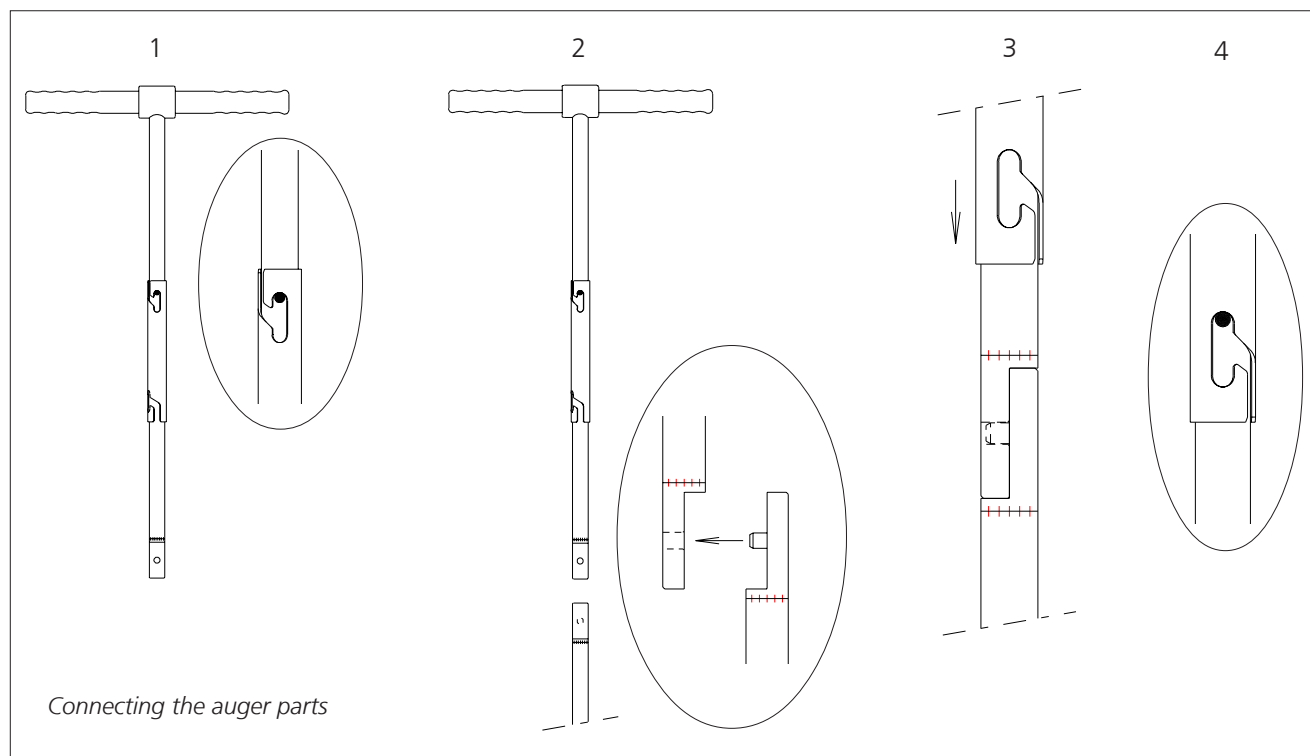

- 4.1 Hold the coupling sleeve in the middle and slide it onto the upper part until it clicks on the nipple (step 1). The sleeve is locked when it cannot be rotated.
- 4.2 Hook the upper part to the bottom part (step 2)
- 4.3 To lock the connection, unscrew the sleeve from the upper part, and slide it across the connection (step 3) and click it onto the nipple (step 4). Check the lock. Notice it will have a slight play.



Hold the coupling sleeve in the middle, this will prevent you from catching the skin of your hands between the parts while (dis)connecting them.

5. The use of gouge augers

5.1 Single gouge augers for more or less soft soils

1. Push the gouge auger vertically into the soil without rotating it. Take a sample with a maximal length equal to the operational length of the auger. Cut off the sample by rotating the auger.



Rotating the auger with sample facilitates hoisting and prevents loss of sample. Cut off the sample by rotating the auger a full circle without pressing down.

3. To withdraw the auger after sampling, pull it upward gently while rotating it. Rotating will prevent loss of sample and counterbalance the underpressure below the auger.



Keep your back straight and your knees bent to prevent injuries when hoisting the auger.

4. Use a bent spatula to cut off protruding soil along the auger's cutting edges, this will provide an almost cylindrical, undisturbed profile suitable for investigation or sampling.

5. Push out the sample using the rounded side of the spatula.



Empty the gouge auger with a bent spatula. Make sure not to touch the cutting edges; they are very sharp. Inappropriate use may cause you to cut your hands.



Fill the borehole with soil or with special bentonite plugs after augering. This will prevent humans or animals to trip into the hole and incur injuries. In addition, it will allow impermeable soil layers to recover.



Be cautious during a thunderstorm. Lightning strokes often occur in the open field, in particular when holding a metal auger.

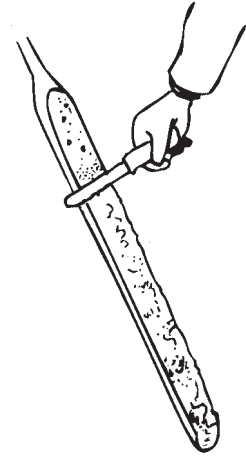

Remarks:

Should you encounter considerable vertical resistance, then horizontal resistance may occur as well. This may cause torsion of the auger body, especially when working at a greater operational depth. It will help to revolve the auger occasionally without pressing down.



Do not do this too frequently; the sample may lose its firmness, and loss of sample may occur. In harder soils you may opt for shallower sampling.



Do not force, or pound on, the auger. Pounding may cause serious damage, such as cracks or snapped joints. Forcing may distort the auger body.

Soil types may vary, necessitating the use of different types of augers (see 6. Applications)

5.2 Single gouge augers for hard soils

1. Position the gouge auger with heavy-duty auger body vertically on the ground and hold the handle with one hand.

2. Use the impact-absorbing steel hammer to drive the gouge auger into the soil. Used properly, this hammer is safe and will not cause the sample to fall apart. Take a sample of maximally 110 cm.



Always utilise the impact-absorbing steel hammer if force is necessary. This is safer and will prevent damage to the auger. Avoid using standard metal hammers. This may cause damage to the auger and a bouncing hammer may lead to injuries.

3. Cutting, hoisting and sampling take place as described as in paragraph 5.1.

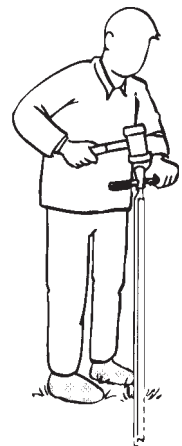

5.3 Single gouge auger set for very hard soils

1. Attach the handle to the Purckhauer gouge auger, insert the gouge auger several centimetres vertically into the ground and remove the handle.
2. Drive the auger into the ground using the steel hammer with nylon head to a depth of your choice (maximally 100 cm). Re-attach the handle to the auger.
3. Cut off the sample by rotating the auger a full circle without pressing down. Remove the handle again.
4. Use the gouge auger pulling set to withdraw the gouge auger:
 - 4.1 Rest the hammer on its head, the indentations on the handle facing the gouge auger.
 - 4.2 Slide the square ring over the handle. Put the eye on the lever over the pin on the square ring, and insert the lever's pin into the hole in the top end of the gouge auger (see figures). The pin on the square ring now functions as the axis of leverage.
 - 4.3 Hold the hammer's handle with one hand and push the lever down with your other hand. This will pull the auger up.
 - 4.4 Lift the lever slightly to allow the ring to slide some indentations up for full withdrawal of the auger.

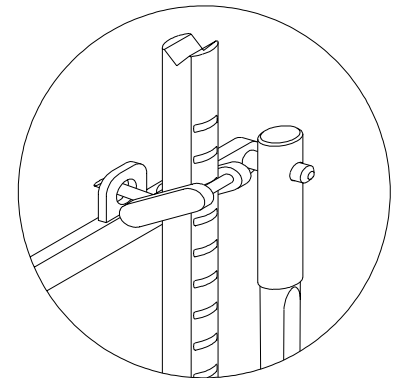
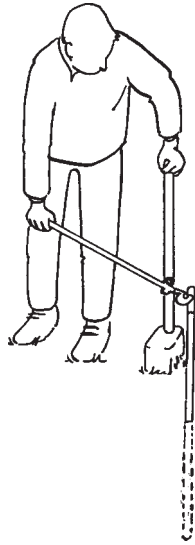

5. Empty the auger with sample using the bent spatula. Use the whetted end of the handle or the bottom end of the hammer's handle.

5.4 Bi-partite gouge auger sets

Usage of the bi-partite gouge augers is similar to that of single gouge augers. See paragraph 5.1 for usage of gouge augers for soft soils, and paragraph 5.2 for hard soils.

Differences:

- Bi-partite gouge augers can be operated at greater depth.
- Bi-partite gouge augers can be extended when augering over 1.20 m, using one or more extension rods.
- Bi-partite augers over 4 m are hoisted and inserted in smaller parts.
- The bi-partite sets consist of a push/pull handle and an Edelman combination type auger.
- The bi-partite gouge auger sets for soft soils permit incremental augering.

Augering at greater depth.

The bi-partite sets are suitable for augering up to a depth of 5 m. Bear in mind that:

- Frictional resistance tends to increase when augering at greater depth, using a same diameter. A combination of suction (when hoisting the auger) and weakness of the soil causes the borehole to be more tight. This can be solved by honing the borehole after two augerings (depending on the situation). Rest the auger on the bottom of the borehole and hoist it while rotating.
- An extended auger should always be pressed down in a fixed position.

 **Always insert the auger holding it in a fixed position, for example with the rounded side of the blade towards you. This will allow you to easily drive the auger through the auger hole**

- When a moderately cohesive layer precedes a cohesive layer, use an Edelman auger before augering.
- To allow working in a comfortable position, Eijkelpark Agrisearch Equipment also has 25- and 100-cm upper parts available.

Attaching the extension rods.

Bayonet connections: slide the sleeve upward and lock it onto the upper part. Unclamp the upper and bottom part. Take an extension rod and a coupling sleeve. Click the sleeve into position on the bottom end of the extension (the end with a hole). Attach the upper and bottom part to the extension. Make sure the coupling sleeve is put well into position!

 **Attach extension rods to the upper end of the gouge auger, directly below the upper part. The rods tend to bend and are followed by the line of the auger hole.**

An auger over 4 m should be inserted and hoisted in parts:

 **Handle the auger in parts. This will prevent damage to the rods and reduce the risk of being hit by augers tipping over.**

1. Hold the bottom part of the auger in the borehole while it comes out for approximately 50 cm. Grip the bottom part firmly to prevent it from dropping into the auger hole.

2. To detach: unclamp the upper and bottom part. Bayonets: slide the sleeve upward and lock it onto the upper part.

To connect: clamp the two parts. Bayonets: slide the sleeve down from the upper part across the connection and lock it onto the bottom part of the auger.

 **Make sure to reconnect the parts in the same order. The rods tend to bend and are followed by the line of the auger hole.**

Push/pull handle.

In the case you need to withdraw the auger and the handle's position is not comfortable to hold, use the push/pull handle (see figure). The push/pull handle is ideal for insertion or withdrawal of the auger without straining your back. It is clamped around the extension rods at any desired height.

The push/pull handle may also be operated by two persons. To that purpose, clamp the handle perpendicularly to the direction of the auger's top handle. Face the other person holding the bars of the push/pull handle with your right hand and holding the bars of the top handle with your left hand exerting up-or downward pressure.

The Edelman auger combination type.

The Edelman auger is utilised to auger a moderately cohesive layer, or to enlarge the auger hole to reduce friction when augering.

1. Hold the auger by its handle and rest it vertically on the ground (see figure, next page).

2. Upon 2¼ rotations the auger should have dug 10 cm. The auger body will be filled up to its bracket with slightly disturbed soil material. Depending on the type of soil additional rotations may be necessary.

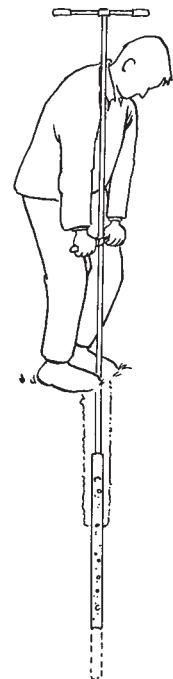

 **Always rotate an auger clockwise!**

3. Cut off the sample and hoist the auger while gently rotating it.

4. To release the cohesive material hold the auger askew on the surface (see figure), rotate the auger 180° while pressing it into the ground. The sample should detach itself and can be taken out by hand or by lightly tapping the auger. Moderately cohesive material will detach itself immediately. Now, examination is possible.

Caution:

- Do not overfill the auger body. Superfluous material will coat the auger hole, which hinders pulling out subsequent soil samples. When augering under the water table an overfilled auger acts like a plunger, which hampers hoisting the auger and results in loss of sample material.
- Prevent the loss of sample material. Hoist the auger with sample while lightly rotating it, do not pull it straight out.

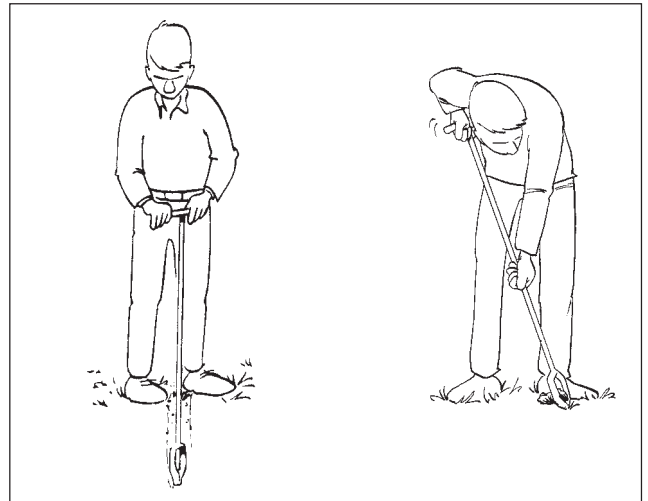

Incremental augering.

Frictional resistance tends to increase when augering at greater depth using a same diameter. Consequently, the auger hole needs honing. To reduce friction use the bi-partite gouge auger set for softer soils to carry out an incremental augering. In this process two or three auger diameters are being used:

1. Pre-auger, using a 60-mm gouge auger
2. Continue, using a 30-mm gouge auger
3. If necessary, use a 20-mm gouge auger for sampling prior to continue with other types of augers. Empty the auger using a narrow, bent spatula. Auger the same hole again, using a 30-mm or 60-mm gouge auger. The diameter of the extension rods do not permit augering at greater depth with a 20-mm gouge auger.

6. Applications

Gouge augers are used in cohesive soils. The standard types are suitable for use in soils with little or moderate penetrating resistance. For hard soils gouge augers have been developed with a heavy-duty auger body and a beating head. They are driven into the soil using a special impact-absorbing hammer. For very hard or stony soils the Purckhauer gouge auger is ideal. It is driven into the soil using a heavy nylon hammer and hoisted with a special pulling set.

The gouge auger sets for soft soils consist of gouge augers with auger bodies of different operational depths and diameters. The optimal operational depth depends on the penetrating resistance of the soil, type of soil, and augering depth. The longer the auger body, the more susceptible the auger will be to torsion. It is recommended to use a short auger body in hard soils. The optimal diameter depends on the composition and structure of the soil, as well as on the research objectives. As a rule, fine-grained or packed soils demand a smaller diameter than loose soils.

The choice of type of connection depends on the purpose of the job at hand.

Since gouge augers produce hardly disturbed samples, they are often used in:

- Surveying
- Soil assessments
- Education
- Rootage surveys
- Fertiliser research
- Clay-inventories
- Paleontological research

The tables below list various applications of gouge augers and different types of connections for bi-partite augers.

| Set | Applications |
|------------------------------|---|
| Single gouge auger sets | Pedological research of surface layers in cohesive soils; to obtain minimally disturbed samples with a wide profile range. |
| Bi-partite gouge augers sets | Pedological research in cohesive soils up to a depth of 5 m; to obtain minimally disturbed samples with a wide profile range. |

| Type of auger | Applications |
|--|---|
| Standard gouge auger, operational depth 50 cm | Soils with moderate penetration resistance; short profile range. |
| Standard gouge auger, operational depth 100 cm | Soils with low penetration resistance; long profile range. |
| Standard gouge auger, diameter 20 mm | Soils with low penetration resistance, incremental augering with sampling. |
| Standard gouge auger, diameter 30 mm | Soils with low penetration resistance, final stage of deeper, incremental augering. |
| Standard gouge auger, diameter 60 mm | Soils with low penetration resistance, initial stage of deeper, incremental augering. |
| Heavy-duty gouge auger (with beating head) | Soils with strong penetration resistance; soils containing debris. |
| Purckhauer gouge auger | Soils with very strong penetration resistance; stony soils. |
| Edelman auger combination type, diameter 7 cm | Pre-augering in moderately cohesive soils, honing to reduce frictional resistance. |

| Type of connection | Applications |
|--------------------|--|
| Bayonet | Easy connection, ideal for augering at greater depth. |
| Conical thread | Rigid connection (no play), suitable for pounding or for perfectly straight auger holes. |

7. Troubleshooting

- Soil particles between the augering rod and the coupling sleeve have caused the sleeve to jam. Pour clean water in one direction in the sleeve, this will flush out the particles. Hold the spatula by the blade and use its synthetic backside to tap the sleeve, coarse particles will come loose, thereby allowing the sleeve to slide. In winter conditions, icing up may cause the sleeve to jam.
- Augering is strenuous; the auger does not screw well into the soil. Take a short sample and cut it off. When augering at greater depth, make sure to hone the auger hole between samples. In stiff soils, use a heavy-duty gouge auger. Pre-auger, using the Edelman auger, in hard and non-cohesive soils. When using the bi-partite set for soft soils, incremental augering may be carried out.
- Loss of sample during augering. This may be caused by prematurely cutting off the sample, which leads to reduced cohesion. Take a shorter sample. Loss of sample may also be caused by changing soil types (encountering moderately cohesive soils).

- ❑ Bayonets: make sure not to lose the coupling sleeves. Count them after augering. Carry them attached to an extension rod or to an upper part. Always check whether the sleeves are locked. Two spare sleeves are provided.
- ❑ The conical thread connections are hard to loosen. Keep the thread clean to ensure easy movement. Use spanner 20x22.
- ❑ Oxidation of the augers in the carrying bag. Dry the equipment before stowing; the carrying bag does not breathe.

8. Maintenance

- ❑ It is recommended to keep the augering equipment in good condition by rinsing it during use. Use a stainless steel brush to clean the conical thread connections.
- ❑ Clean the augers after use with running water. Take off the coupling sleeves from the rods and the upper parts, clean and dry them well to keep the insides smooth and prevent oxidation (rough inner surfaces of the sleeve may cause it to jam). Stow away the equipment in the carrying bag after drying.
- ❑ The auger bodies need no whetting, use keeps them sharp-edged. Under normal conditions oxidation is not detrimental to the auger and will vanish upon use.

Nothing in this publication may be reproduced and/or made public by means of print, photocopy, microfilm or any other means without previous written permission from Eijkelkamp Agrisearch Equipment.

Technical data can be amended without prior notification.

Eijkelkamp Agrisearch Equipment is interested in your reactions and remarks about its products and operating instructions.