

1920F1

OPERATING INSTRUCTIONS

1920F1 Pressure-Vacuum Soil Water Samplers

July 2007

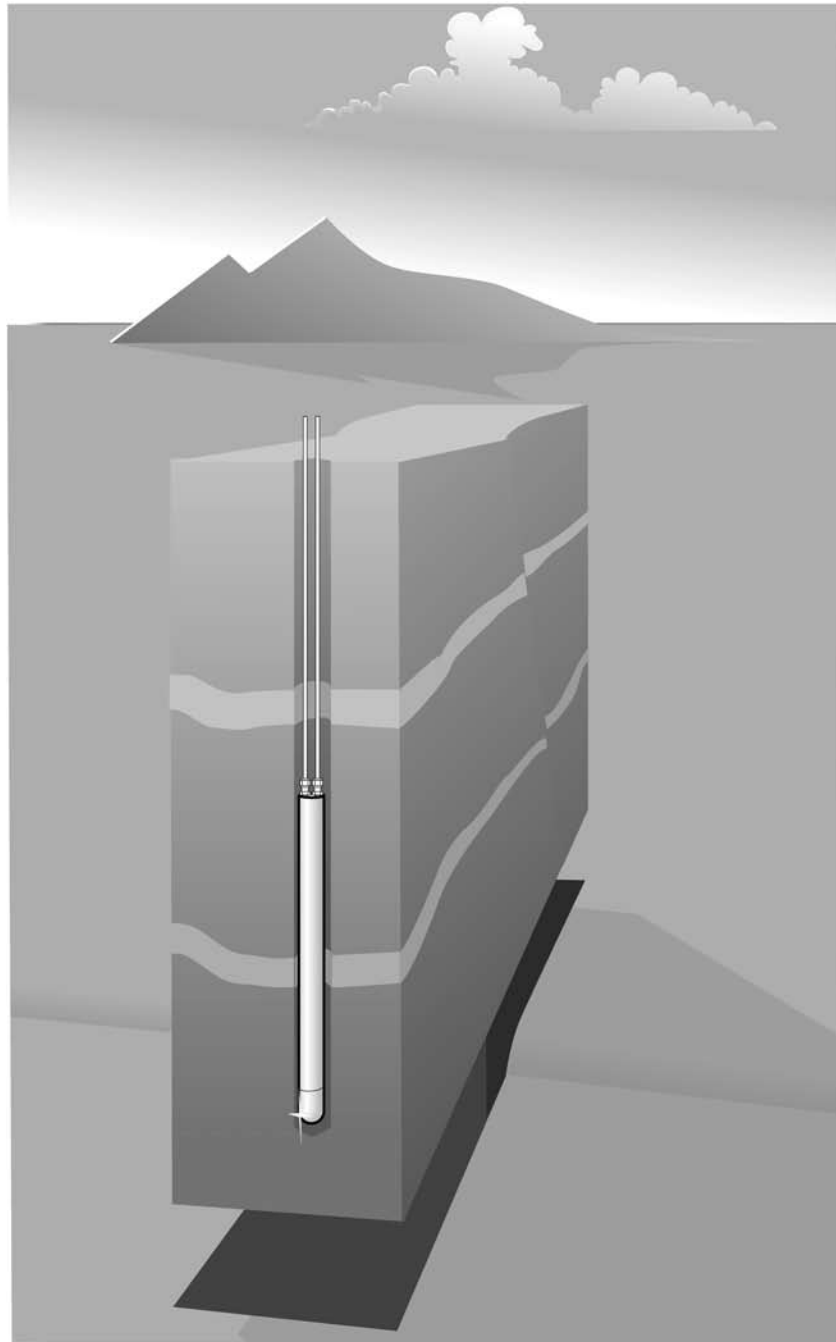

SOILMOISTURE EQUIPMENT CORP.
P.O. Box 30025, Santa Barbara, California 93130 USA
Phone: (805) 964-3525 • Fax: (805) 683-2189
e-mail: sales@soilmoisture.com • Web www.soilmoisture.com



TABLE OF CONTENTS

History/General Uses	Page 3
Operating Principles	Page 4
Your New Pressure-Vacuum Soil Water Sampler.....	Page 7
Unpacking	Page 7
Assembly	Page 7
Not Liable for Improper Use.....	Page 7
Acquaint Yourself with the Parts.....	Page 8
Requirements Prior to Use and How to Operate.....	Page 9
Attaching the Access Tubes.....	Page 9
Pressure Testing Before Installation	Page 9
Coring the Hole.....	Page 9
Preparing The Hole Using a Slurry and Backfilling The Hole	Page 10
Alternate Methods for Sampler Installation	Page 11
Collecting a Sample in the Sampler.....	Page 13
Recovering a Sample from the Soil Water Sampler	Page 14
Maintenance and Precautions.....	Page 15
Re-wetting The Sampler	Page 15
Spare Parts and Accessories	Page 16

HISTORY/GENERAL USES

Soil Water Samplers had their origin back in 1961 when we cooperated with Dr. George H. Wagner at the University of Missouri to manufacture a porous ceramic cup for collecting soil water samples. The outgrowth of this work was our first commercial Soil Water Sampler, Model 1900 Soil Water Sampler. Since that time, these samplers have been generally accepted as an ideal tool for in situ collection of soil water samples for a great variety of soil moisture monitoring work.

The initial and most extensive use of these Samplers was made by Pennsylvania State University, largely under the direction of Dr. L. T. Kardos and others, on the Pennsylvania Waste Water Project. Modifications of the original 1900 Soil Water Sampler by Richard R. Parizek and Burke E. Lane at Pennsylvania State University, reported on in the Journal of Hydrology, produced a pressure-vacuum type unit. Since that time, we have made available commercially the Model 1920 Pressure-Vacuum Soil Water Sampler. Some of our Soil Water Samplers have been in continuous use for several years and still yield satisfactory soil moisture samples.

All of our ceramics are made from formulations which contain various proportions of kaolin, talc, alumina, ball clay, and other feldspathic materials, using proprietary formulas developed through research and experience accumulated over more than 4 decades.

Our samplers find applications not only in research work such as quantitative chemical analysis of soil water, but also for pollution control purposes in monitoring moisture under sanitary landfills, irrigated areas with wastewater, and areas where reclaimed or recycled water is used on a routine basis to assure compliance with government standards.

Soilmoisture's line of Soil Water Samplers has proven to be an excellent and reliable means for obtaining soil water samples from both saturated and unsaturated soils at depths ranging up to several hundred feet.

OPERATING PRINCIPLES

Soilmoisture's Soil Water Samplers, which are also referred to as "suction lysimeters" or "lysimeters", have been in general use around the world for many years.

Soil water is held largely under a state of tension (negative pressure) within the soil by capillary forces. The capillary force is the sum of the adhesive and cohesive forces. The adhesive force is characterized as the attraction of water for soil solids (soil and organic matter). Cohesive force is characterized as the attraction of water for itself. Adhesive force is far greater than the cohesive force.

Water is naturally attracted to soil particles (by its adhesive quality) and "sticks" to the surface of each particle and in the various sized "capillary" spaces or "pores" between the soil particles. When the soil is very wet, the large pores fill with water. This "excess" water has no direct surface contact with the soil and is held cohesively, one water molecule to another, and can move quite freely. As a soil dries out, the "excess" water first evaporates as it requires less energy to break the cohesive bonds. The remaining water, held tightly inside the capillary spaces by adhesive qualities, requires more energy to remove it from the soil.

The following illustration (see Figure 1) shows the increasing force required to remove water from the small-sized capillary pores compared to the large pores as the soil dries out. When the remaining water is held only in extremely small pore spaces, it requires more energy to remove the water from these pores. Even though there may be a considerable volume of water in the soil, the tension that holds the water determines how readily it can be removed.

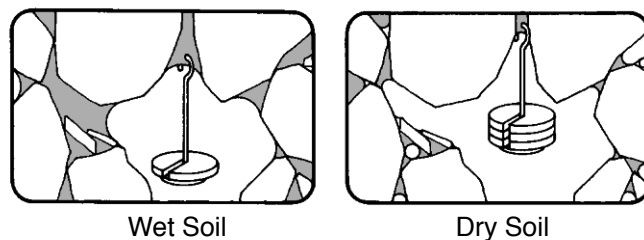

Figure 1.

This tension that determines how moisture moves in the soil is referred to as "soil water tension", "negative pore pressure", or "soil suction". For simplicity's sake we refer to this tension as "soil suction" in these instructions, but keep in mind that negative pressure is the most descriptive term.

The following graph shows the relationship between the percent of moisture in a soil and the soil suction required to remove the moisture from three types of soil: clay, loam, and sand.

The graph (see Figure 2) illustrates that it is easier to remove water from a sandy soil with 10% moisture, than it is to remove water from a clay soil with 30% moisture. This is because the water in the clay soil is held in very small capillary spaces within the soil particles under a higher soil suction, whereas the sandy soil holds water in large capillary spaces under a lower soil suction.

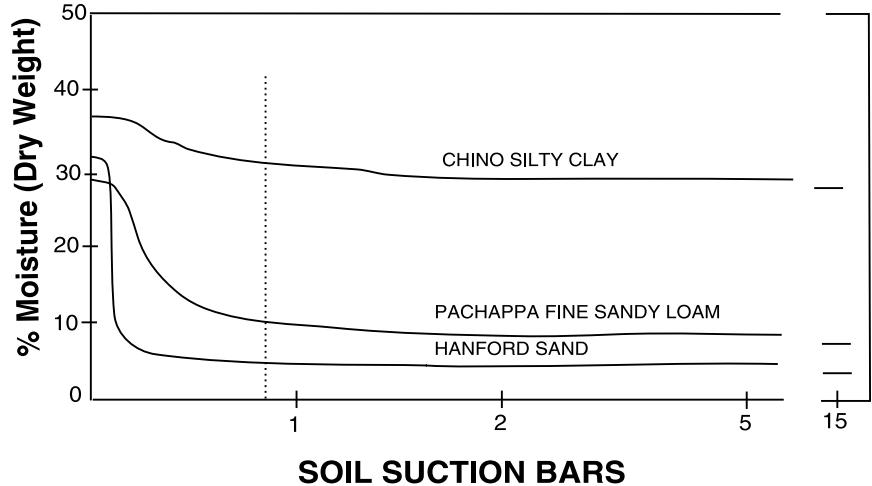

Figure 2.

Soilmoisture's Soil Water Samplers allow water to be removed from the soil by creating a vacuum (negative pressure or suction) inside the sampler greater than the soil suction holding the water in the capillary spaces. This establishes a hydraulic gradient for the water to flow through the porous ceramic cup and into the sampler. Note: when evaluating soil suction ratings of a ceramic plate or cup, a positive pressure rating is used. Water can be held at tensions far greater than 1 atm (the limit for vacuum-type measurements). Positive pressure can force water out of capillary pores equivalently as negative pressures, and is the practical method for evaluation of soil suction.

In practice, a vacuum is drawn in the Soil Water Sampler that exceeds the soil water tension. Then liquid water will flow to the ceramic cup due to the potential gradient (i.e. water will move from less negative potential to more negative potential). The practical limit for water flow in soils is about 65 cb (centibar) (although in some soils, the value can approach 85 cb). When soil moisture tensions exceed 2 bars, the wetted meniscus in the ceramic pores will break and the Soil Water Sampler will appear to be unable to hold vacuum. The ceramic cup will have to be rewetted to hold a vacuum and soil moisture tensions will have to decrease to less than 85 cb before water can again be moved toward the ceramic cup.

Additional information on the advantages and disadvantages of Soil Water Samplers in general can be found in Chapter 19, "Compendium of In Situ Pore-Liquid Samplers for Vadose Zone" (Dorrance et al.), of the ACS Symposium on Groundwater Residue Sampling Design (April 22-27, 1990) and the ASTM Designation D4696-92 "Standard Guide for Pore-Liquid Sampling from the Vadose Zone" (Vol. 04.08 Soil and Rock (I): D4696).



YOUR NEW PRESSURE-VACUUM SOIL WATER SAMPLER

Unpacking

Remove all packing materials and check the Soil Water Sampler for any damage that may have occurred during shipment.

If the Sampler is damaged, call the carrier immediately to report it. Keep the shipping container and all evidence to support your claim.

Assembly

The standard 1920F1 Pressure-Vacuum Soil Water Sampler was assembled and tested prior to shipment.

All other accessory items necessary for proper use are discussed later in these instructions and are listed on page 16. Please read all instructions thoroughly before installing the Sampler. To assure optimum cleanliness of the assembly, no grease or organic solvents have been used in its manufacture.

Not Liable for Improper Use

Soilmoisture Equipment Corp. is not responsible for any damage, actual or inferred, for misuse or improper handling of this equipment. The Pressure-Vacuum Soil Water Samplers, Models 1920F1, are to be used solely as directed by a prudent individual under normal conditions in the applications intended for this equipment.

ACQUAINT YOURSELF WITH THE PARTS

The Pressure-Vacuum Soil Water Sampler (Model 1920F1) comes fully assembled. The Pressure-Vacuum Soil Water Sampler (see Figure 3) is constructed of a 1.9 inch O.D. PVC tube (made of FDA-approved material) with a 2 bar porous ceramic cup bonded to one end. The serviceable end of the Sampler is completely sealed and two 1/4-inch tube connectors protrude from the top. The white tube connector indicates the "Pressure/Vacuum" side and is used exclusively for pressurizing and evacuating the Sampler. The green tube connector is used to recover the collected sample.

Two 1/4-inch O.D. polyethylene access tubes are used for pressurizing and recovering samples which are terminated in neoprene tubing. Clamping rings are used to clamp the neoprene to keep the Sampler under negative pressure (not shown here).

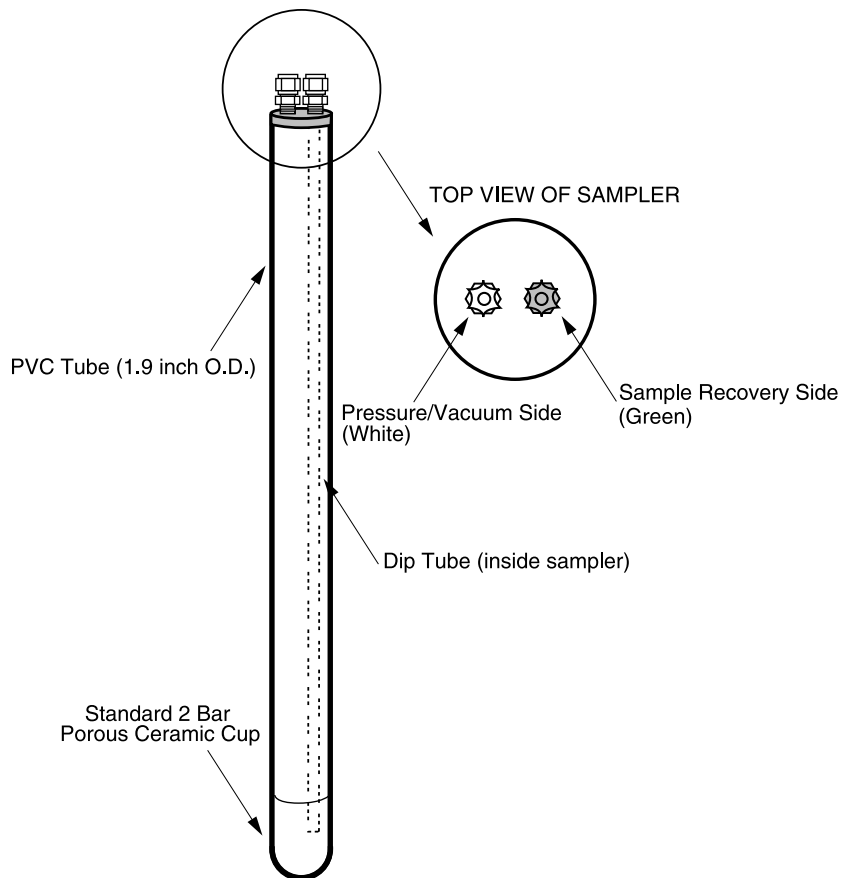

Figure 3. Pressure-Vacuum Soil Water Sampler

REQUIREMENTS PRIOR TO USE AND HOW TO OPERATE

Attaching the Access Tubes

Once the depth and location for the Pressure-Vacuum Soil Water Sampler have been established, you must determine the required length for the access tubes before they are cut and attached to the Soil Water Sampler.

The access tubes are generally made of 1/4-inch O.D. polyethylene, nylon, or teflon tubing. Each access tube is inserted into the loosened top portion of the tube connector located on the serviceable end of the Soil Water Sampler. Tighten the fittings to finger tightness. We recommend using 2 different colors of tubing to differentiate between the two connectors in order to eliminate mistakes in identifying the access tubes once the Sampler is placed in the soil. Soilmoisture offers both black and green polyethylene tubing, models 1903L and 1904L respectively.

Pressure Testing Before Installation

We highly recommend pressure testing the complete Sampler assembly prior to installation. Your prior testing will confirm the integrity of all joints and components.

After allowing the ceramic portion of the Sampler to soak in water for approximately two hours, a sustained pressure of 20 psi can be applied to the submerged Sampler, associated tubing, and connectors. Continuous bubble formation indicates leakage and shows the exact location of any leak.

Coring the Hole

The Pressure-Vacuum Soil Water Sampler, Model 1920F1, may be installed at any depth up to a maximum of 50 feet.

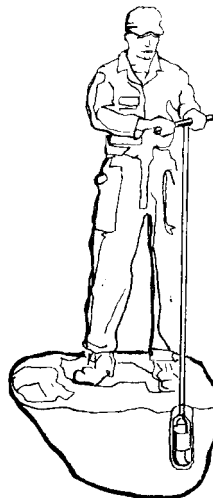

Figure 4a.



Figure 4b.

In rock-free, uniform soils at shallow depths, use a 2-inch screw or bucket auger for coring the hole (Figure 4a). If the soil is rocky, a 4-inch auger should be used. The soil is then sifted (Figure 4b) through a 2mm mesh screen or 2mm sieve to free it of pebbles and rocks.

This will provide a reasonably uniform backfill soil for filling in around the Soil Water Sampler. Soilmoisture has suitable soil augers for this purpose (234 Series augers). There are other methods for installing the Soil Water Sampler to be used, largely dictated by the type of soil you are dealing with and the tools available. The primary concern in any method of installation is that the porous ceramic cup of the Sampler be in tight, intimate contact with the soil so that soil water can move readily from the pores of the soil through the pores in the ceramic cup and into the Soil Water Sampler.

Preparing The Hole Using a Slurry and Backfilling The Hole

After the hole has been cored, mix sifted soil with water to make a slurry which has a consistency of cement mortar. This slurry is then poured down to the bottom of the cored hole to insure a good soil contact with the porous ceramic cup (see Figure 5a).

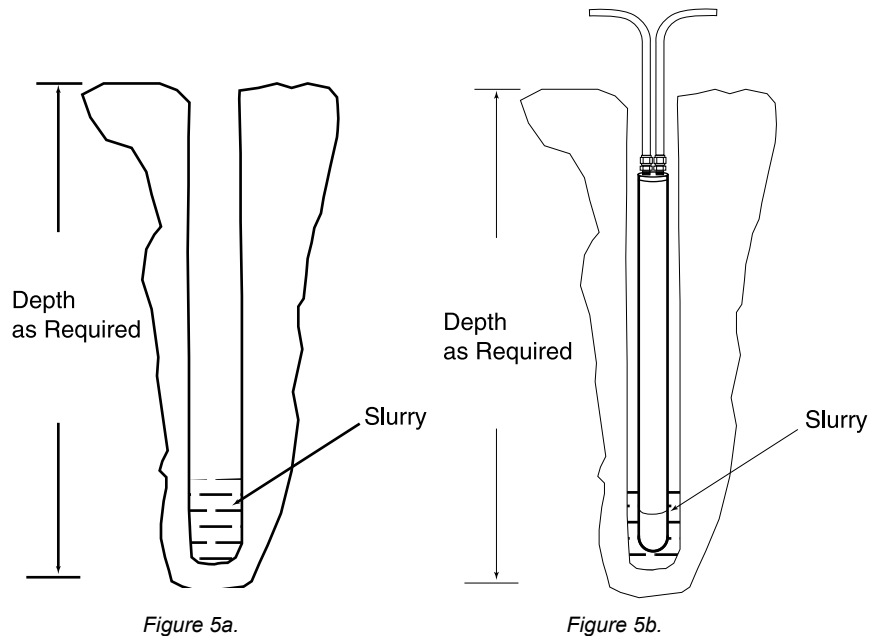

Immediately after the slurry has been poured, insert the Soil Water Sampler down into the hole so that the porous ceramic cup is completely embedded in the soil slurry (see Figure 5b).

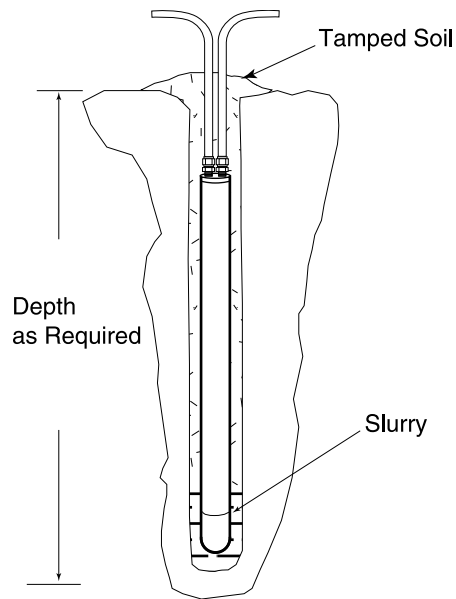

Figure 6.

Backfill the remaining area around the Sampler with sifted soil which is free of pebbles and rocks, a 2mm sieve is popular for this. Tamp the soil firmly to prevent surface water from running down the cored hole, or make a bentonite seal. (see Fig. 6)

Alternate Methods for Sampler Installation

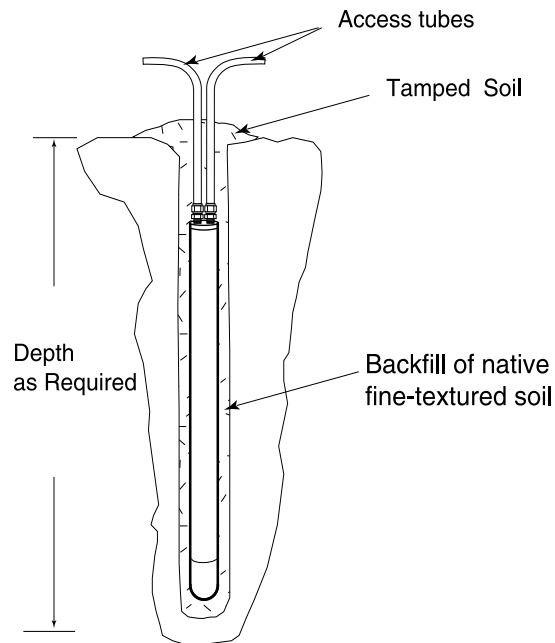

Figure 7.

If the soil into which the Sampler is being installed is fine-textured and free of rocks, a slurry may not be necessary. Core the hole to the desired depth, insert the Soil Water Sampler and backfill the hole with native soil, tamping continuously to insure good soil contact with the porous ceramic cup and complete sealing of the cored hole (see Figure 7).

In a coarse-textured or rocky soil, it may be difficult to make a suitable slurry from the existing soil. A slurry can be made using silica flour, which is then used to establish good contact between the ceramic cup and the soil. For a 2-inch diameter hole, 1 lb. of silica flour is needed, while a 4-inch diameter hole will require 4 lbs. of silica. Mix the silica with water to produce a slurry with a consistency of cement mortar.

Core the hole to the desired depth, and pour in about 1/4 of the silica slurry. Insert the Soil Water Sampler and pour in the remainder of the slurry so that the slurry completely covers the ceramic cup. Backfill the hole with sifted soil (free of pebbles and rocks), tamping continuously with a metal rod to prevent surface water from channeling down between the soil and the body tube of the Sampler (see Figure 8).

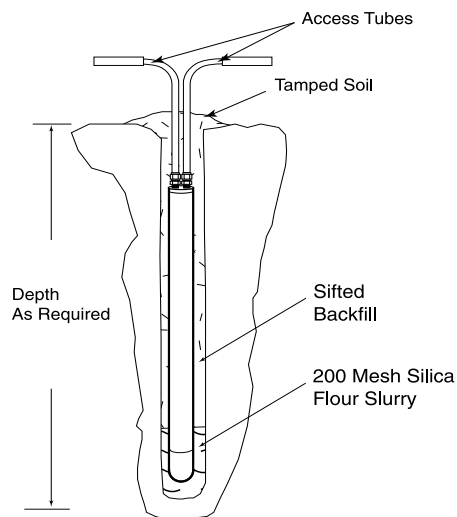

Figure 8.

To ensure that disturbed soil resulting from the installation of the Sampler does not affect the movement of water to the Sampler, Bentonite clay plugs can be installed. Core the hole a few inches deeper than the desired depth, and pour in several inches of wet Bentonite clay (see Fig. 9). This will isolate the Sampler from the soil below. Pour in 1/4 of the slurry, either of soil or of Silica, and insert the Soil Water Sampler. Pour the remainder of the slurry around the cup of the Soil Water Sampler. Backfill with native soil to a level just above the Soil Water Sampler and again add sufficient Bentonite as a plug to further isolate the Soil Water Sampler and guard against possible channeling of water down the hole. Backfill the remainder of the hole slowly, tamping continuously with a metal rod using native soil, free of pebbles and rocks.

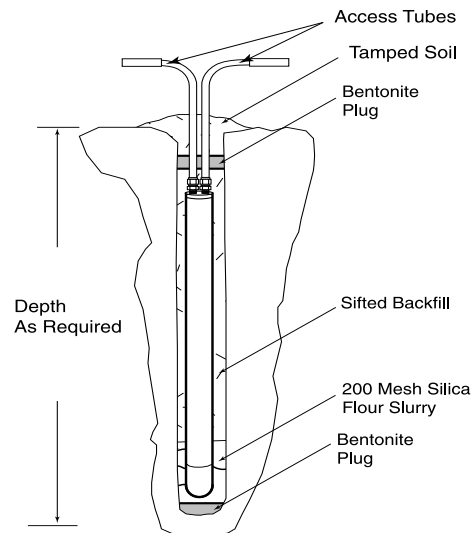

Figure 9.

Protecting the Access Tubes

After installation, the access tubes from the Sampler are terminated with a 6-inch length of neoprene tubing (MRT003) above the Sampler installation. Or, if conditions require, place the neoprene-terminated access tubes in a trench, terminating above the soil surface at a remote location. We recommend that the access tubes be protected inside a conduit tube running from the top of the Sampler to the termination at the surface. At the surface level, take care that the access tubes are safe from damage by mechanical equipment or animals. Do not cover the surface area directly above the Sampler in any manner that would interfere with the normal percolation of soil water down to the depth of the Sampler, otherwise the obstruction could have an adverse affect on your soil water sample.

Collecting A Sample in the Sampler

To collect a sample, the discharge access tube is closed using a clamping ring, and the vacuum port of the hand pump is connected to the Pressure-Vacuum access tube. The pump is then used to create a vacuum of about 60 cb inside the Sampler, which is indicated on the gauge connected to the pump (see Fig. 10).

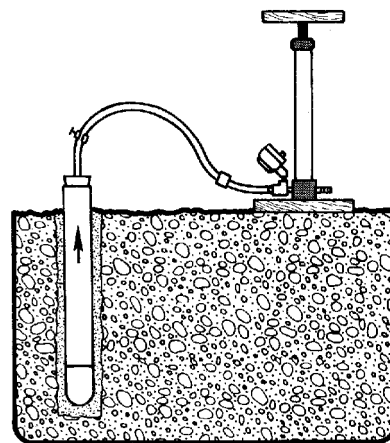

Figure 10.

The vacuum within the Sampler causes the water to move from the soil,

through the pores of the porous ceramic cup, and into the Sampler. The rate at which the soil solution will collect within the Sampler depends on the capillary conductivity of the soil, the soil suction value within the soil (as measured with tensiometers), and the amount of vacuum within the Sampler. In moist soils of good conductivity, at field capacity (10 to 30 cb of soil suction as read on a tensiometer) substantial soil water samples can be collected within a few hours. Under more difficult conditions it may require several days to collect an adequate sample.

Recovering a Sample from the Soil Water Sampler

In general, a vacuum of 50 to 85 cb is normally applied to the Soil Water Sampler. In very sandy soils, however, it has been noted that very high vacuums applied to the Soil Water Sampler seem to result in a lower rate of collection of the sample than a lower vacuum. It is our opinion that in these coarse, sandy soils, the high vacuum within the Sampler may deplete the moisture in the immediate vicinity of the porous ceramic cup reducing the capillary conductivity, which creates a barrier to the flow of water to the cup. In loams and gravelly clay loams, users have reported collection of 300 to 500 ml of solution over a period of a day with an applied vacuum of 50 cb, when soils are at field capacity. At waste water disposal sites, users have obtained 1500 ml of sample solution in 24 hours following cessation of irrigation with 1 to 2 inches of waste water on sandy or clay loam soil.

To recover a soil water sample, remove the Pressure-Vacuum tube from the vacuum port of the pump, and attach the tube to the pressure port. Place the discharge access tube in a small collection bottle and remove both clamping rings. Apply a few strokes on the hand pump to develop enough pressure within the Sampler to force the collected water out of the Sampler and into the collection bottle (see Fig. 11).

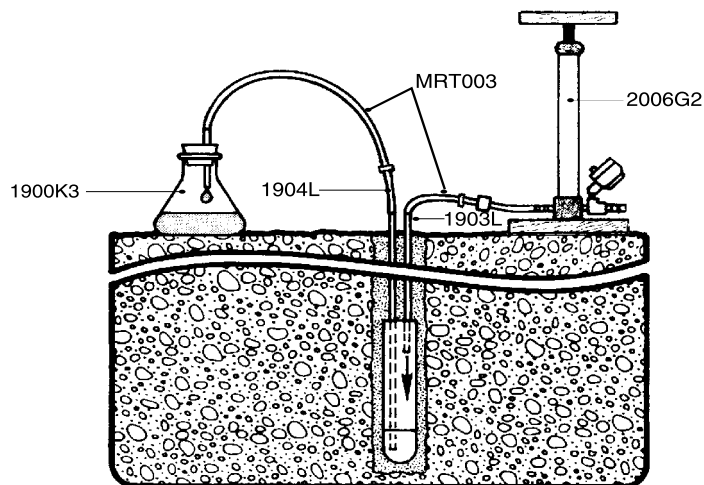

Figure 11.

Subsequent samples are collected by again creating a vacuum within the Sampler and following the steps as outlined above.

There are no maintenance requirements for the Pressure-Vacuum Soil

MAINTENANCE AND PRECAUTIONS

Water Sampler other than protecting the access tubes from damage. Tube ends should be covered or plugged to prevent debris from entering the tubes and later contaminating the Sampler.

Freezing conditions will not damage the subsurface parts of the Samplers. The Samplers are normally left permanently in place all year round. Water may freeze in the sample line near the surface during saturated freezing conditions. Be sure all the water is removed from the sample line before clamping it for the next sample.

If the soil suction exceeds 2 bars, the ceramic cup may need to be rewetted to obtain a sample. This is accomplished by pouring approximately 250 ml of deionized water down the sample line (both the pressure-vacuum and the sample lines must be open). After waiting approximately one hour, pressurize the pressure-vacuum line to remove any excess water. A vacuum can be applied after the ceramic cup has been rewetted. If no sample is obtained after following the above rewetting procedure, the soil suction is probably in excess of 85 cb.

Rewetting The Sampler

SPARE PARTS AND ACCESSORIES LIST

0922W_	Bentonite (5 lb., 10 lb., or 50 lb. bag sizes)
0930W_	Silica Flour (5 lb., 10 lb., or 50 lb. bag sizes)
1900K4	Wide-mouth Sample Bottle, polypropylene - 1,000 ml (autoclavable)
1902K3	Centralizer with Centralizer Adapter Kit
1902K4	1-1/2" Stainless Steel Coupling Assembly
1903L_	Black Polyethylene Tubing (100 ft., 500 ft., or 1,000 ft. rolls)
1904L_	Green Polyethylene Tubing (100 ft., 500 ft., or 1,000 ft. rolls)
2006G2	Pressure-Vacuum Hand Pump (with gauge)
2031G2	Clamping Rings (per doz.)
MRT003	Neoprene Tubing, 3/16-inch I.D. x 1/16-inch wall (10ft, 25ft, or 50ft, rolls)

Note:

All Pressure-Vacuum Soil Water Samplers come in 6-inch, 12-inch, 24-inch or 36-inch lengths. They can also be special ordered with either a 1 Bar High Flow (30 ft. maximum depth range) or 1/2 Bar Standard (15 ft. maximum depth range) porous cup instead of the standard 2 Bar cup. Please contact our Sales Department for further details.

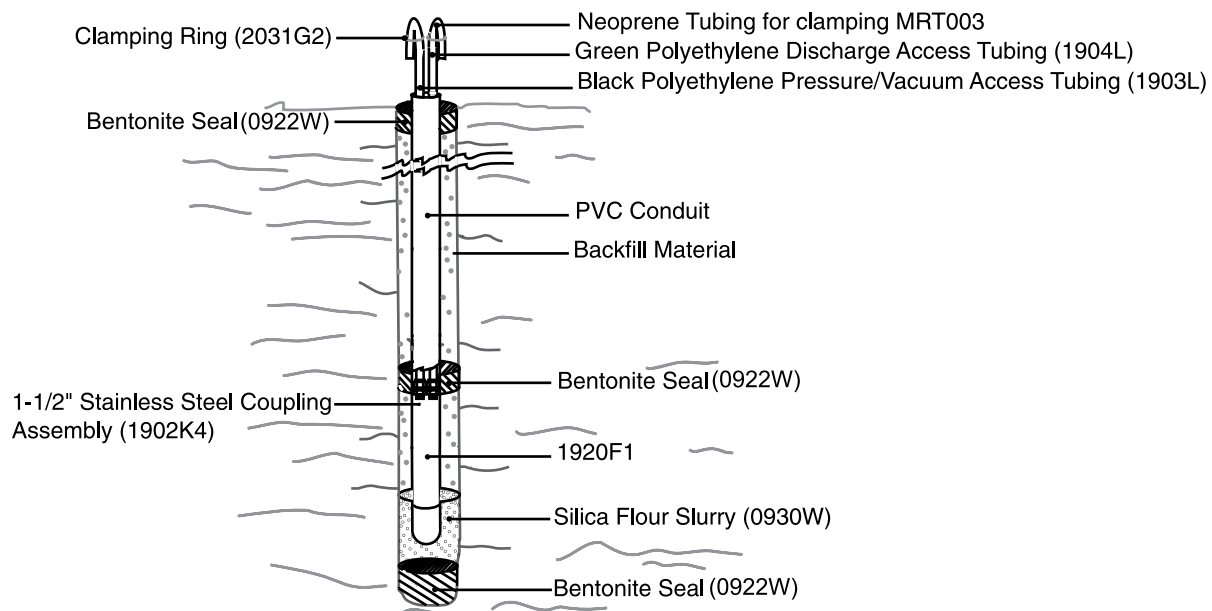

Figure 12. Complete sampler installation with accessories