



**METER**

# **ATMOS 41**



# TABLE OF CONTENTS

<b>1. Introduction.....</b>	<b>1</b>
<b>2. Operation .....</b>	<b>2</b>
2.1 Installation .....	2
2.2 Connecting.....	3
2.2.1 Connect to METER Logger.....	4
2.2.2 Connect to Non-METER Logger.....	5
2.3 Communication .....	6
<b>3. System.....</b>	<b>7</b>
3.1 Specifications.....	7
3.2 Pyranometer .....	12
3.3 Anemometer .....	13
3.4 Vapor Pressure/Relative Humidity Sensor .....	14
3.5 Rain Gauge.....	16
3.6 Temperature Sensor.....	17
3.7 Lightning Sensor .....	18
3.8 Barometric Pressure Sensor .....	19
3.9 Tilt Sensor.....	19
3.10 Theory.....	19
3.10.1 Wind Speed and Direction.....	19
3.10.2 Temperature.....	21
3.11 Limitations.....	22
3.11.1 Snow and Ice Accumulation .....	22
3.11.2 Heavy Rain and Strong Wind .....	23
3.11.3 Electromagnetic Interference.....	23

3.12 Measurements with METER Loggers.....	23
<b>4. Service.....</b>	<b>25</b>
4.1 Calibration .....	25
4.2 Recalibration Recommendations.....	26
4.3 Cleaning and Maintenance.....	26
4.4 Update Firmware .....	28
4.5 Troubleshooting.....	28
4.6 Customer Support.....	30
4.7 Terms and Conditions .....	31
<b>References .....</b>	<b>32</b>
<b>Index .....</b>	<b>33</b>

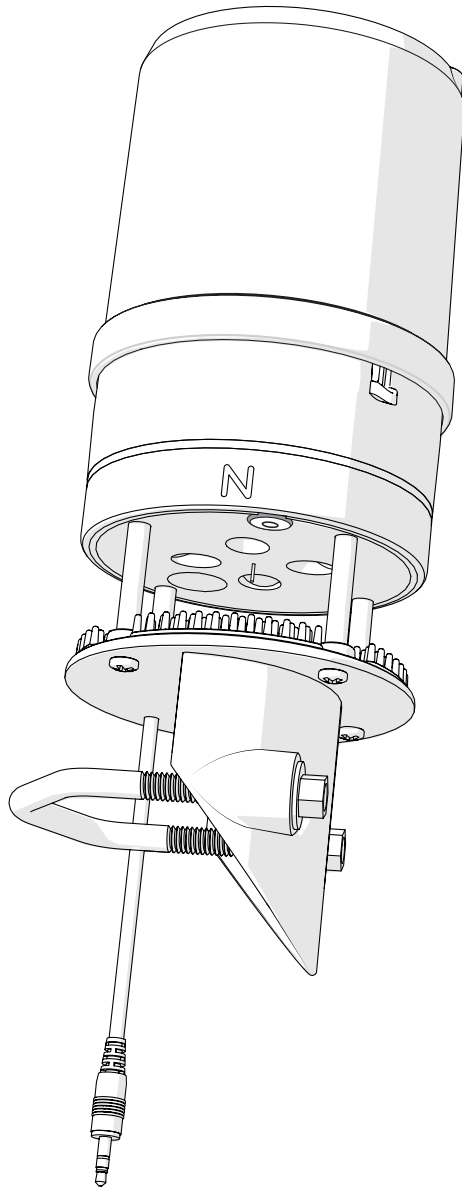

# 1. INTRODUCTION

Thank you for choosing the ATMOS 41 All-in-One Weather Station from METER Group.

The ATMOS 41 All-in-One Weather Station is designed for continuous monitoring of environmental variables, including all standard weather measurements ([Section 3](#)). The ATMOS 41 measures the following:

- Solar radiation
- Precipitation
- Air temperature
- Barometric pressure
- Vapor pressure
- Relative humidity
- Wind speed
- Wind direction
- Maximum wind gust
- Lightning strikes
- Lightning distance
- Tilt

All sensors are integrated into a single, small form-factor unit, requiring minimal installation effort. A robust, no moving parts design that prevents errors because of wear or fouling make the weather station ideal for long-term, remote installations. ATMOS 41 can be used for a variety of applications:

- Weather monitoring
- Microenvironment monitoring
- Spatially-distributed environmental monitoring
- Crop weather monitoring
- Fire danger monitoring
- Weather networks

Additional advantages include its low-power design that supports battery-operated data loggers and the SDI-12 three-wire interface. A tilt sensor warns the user of out-of-level condition, and no configurations are necessary.

Prior to use, verify all ATMOS 41 system components are included and appear in good condition.

## 2. OPERATION

Please read all instructions before operating the ATMOS 41 to ensure it performs to its full potential.

### PRECAUTIONS

METER sensors are built to the highest standards, but misuse, improper protection, or improper installation may damage the sensor and possibly void the manufacturer's warranty. Before integrating ATMOS 41 into a system, follow the recommended installation instructions and have the proper protections in place to safeguard sensors from damage.

## 2.1 INSTALLATION

Follow the steps listed in [Table 1](#) to set up the ATMOS 41 and start collecting data.

**Table 1 Installation**

<b>Tools Needed</b>	<p><b>Wrench</b> 13 mm (1/2 in)</p> <p><b>Mounting pole</b> 31.8 to 50.8 mm (0.25 to 2.0 in) diameter</p> <p><b>NOTE:</b> Smaller mounts are compatible if washers are added to the V-bolt (not included). United States standard pipe sizes that are compatible are 1.00-, 1.25-, and 1.50-in. Square tubing with a width of 1.25 to 2.00 in or T-posts can also work as mounting options.</p>
<b>Preparation</b>	<p><b>Consider the Surroundings</b></p> <p>Ensure that site selection is far from wind obstruction.</p> <p>Make sure surrounding objects will not shade the solar radiation sensor.</p> <p>Choose a site far from sources of high electromagnetic interference (EMI), such as high-voltage power transmission lines. EMI sources adversely affect ATMOS 41 lightning and rainfall measurements.</p> <p><b>Conduct System Check</b></p> <p>Plug the weather station into the logger (<a href="#">Section 2.2</a>).</p> <p>Verify all sensors are functional and read within expected ranges.</p> <p><b>Adjust Pole Height</b></p> <p>Prepare the mounting pole to the appropriate height. Many installations require the ATMOS 41 to be mounted 2 m above ground, but mounting height can be adjusted based on the specific application.</p>
<b>Mounting</b>	<p><b>Install on Mounting Pole</b></p> <p>Use the V-bolt to mount the unit at the desired height. The V-bolt is compatible with most meteorological stands, poles, tripods, and other mounts.</p> <p><b>Mount Toward True North</b></p> <p>Orient the <b>N</b> engraved on the side of the instrument should be oriented to point true north (not magnetic north). The ATMOS 41 must be oriented correctly by hand for accurate wind direction measurements.</p>

Table 1 Installation (continued)

Mounting (continued)	<p><b>Level the System</b></p> <p>Use the bubble level underneath the ATMOS 41 or a PROCHECK display to level the weather station. The angle of the mounting pole may need to be adjusted or shims added to the ATMOS 41–pole interface to achieve level. The ATMOS 41 must be within approximately <math>\pm 2^\circ</math> of dead level (0, 0) in both the X and Y directions to accurately measure rainfall and solar radiation.</p> <p><b>Secure the System</b></p> <p>Tighten the V-bolt nuts by hand until hand-tight, and then gently tighten with a wrench, securing the ATMOS 41 flat and tight against the top of the stand.</p> <p><b>CAUTION:</b> Do not overtighten V-bolt.</p> <p><b>Secure and Protect Cables</b></p> <p><b>NOTE:</b> Improperly protected cables can lead to severed cables or disconnected sensors. Cabling issues can be caused by many factors such as rodent damage, driving over sensor cables, tripping over cables, not leaving enough cable slack during installation, or poor sensor wiring connections.</p> <p>Install cables in conduit or plastic cladding when near the ground to avoid rodent damage.</p> <p>Gather and secure cables between the ATMOS 41 and the data logger to the mounting mast in one or more places.</p> <p><b>Connect to Data Logger</b></p> <p>Plug the sensor into a data logger.</p> <p>Use the data logger to make sure the sensor is reading properly.</p> <p>Verify these readings are within expected ranges.</p> <p>For more instructions on connecting to data loggers, refer to <a href="#">Section 2.2</a>.</p>
-------------------------	--

**NOTE:** ATMOS 41 will not work with legacy Decagon data loggers (Em50 Series and Em5B) because the ATMOS 41 outputs contain too many parameters.

## 2.2 CONNECTING

The ATMOS 41 works seamlessly with METER data loggers. This system will not work with legacy data loggers (Decagon Em5, Em5B, Em50, Em50R, and Em50G) because the ATMOS 41 has too many output parameters (previously limited to three). The ATMOS 41 can also be used with other data loggers, such as those from Campbell Scientific, Inc. For extensive directions on how to integrate the sensor into third-party loggers, refer to the [ATMOS 41 Integrator Guide](#) ([metergroup.com/atmos41-support](http://metergroup.com/atmos41-support)).

ATMOS 41 sensors require an excitation voltage in the range of 3.6 to 15.0 VDC and operates at a 2.8- to 5.5-VDC level for data communication. The ATMOS 41 can be integrated using SDI-12 protocol. See the [ATMOS 41 Integrator Guide](#) for details on interfacing with data acquisition systems.

ATMOS 41 sensors come with a 3.5-mm stereo plug connector (Figure 1) to facilitate easy connection with METER loggers. ATMOS 41 sensors may be ordered with stripped and tinned wires to facilitate connecting to some third-party loggers (Section 2.2.2).

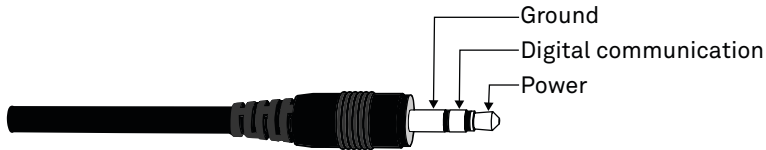

Figure 1 3.5-mm stereo plug connector wiring

The ATMOS 41 comes standard with a 5-m cable. It may be purchased with custom cable lengths for an additional fee (on a per-meter basis). In some instances, the cable can be extended beyond 75 m by the user, but this is discouraged for a variety of reasons. Please contact [Customer Support](#) for more details before extending or splicing cables.

## 2.2.1 CONNECT TO METER LOGGER

The ATMOS 41 works most efficiently with ZENTRA series data loggers. Check the METER [downloads webpage](#) ([metergroup.com/downloads](http://metergroup.com/downloads)) for the most recent data logger firmware. Logger configuration may be done using either ZENTRA Utility (desktop and mobile application) or ZENTRA Cloud (web-based application for cell-enabled data loggers).

**NOTE:** This system will not work with legacy data loggers (Decagon Em5, Em5B, Em50, Em50R, and Em50G).

1. Plug the stereo plug connector into one of the sensor ports on the logger.
2. Use the appropriate software application to configure the chosen logger port for the ATMOS 41. METER data loggers will automatically recognize ATMOS 41 sensors.
3. Set the measurement interval.

METER data loggers measure the ATMOS 41 every minute and return the average of the 1-min data across the chosen measurement interval.

**NOTE:** The ATMOS 41 draws more current than most other METER sensors because it makes frequent wind speed and precipitation measurements. As a result, plugging multiple ATMOS 41 stations into a single ZENTRA or EM60 data logger may have significant impact on battery life. At times or in regions with plentiful sunshine, the solar panel should provide ample charge and this should not be an issue. During the winter or periods of extended heavy clouds, the solar panel may not provide enough charging current to keep the system running with multiple ATMOS 41 units. METER recommends using only one ATMOS 41 per ZENTRA or EM60 data logger.

ATMOS 41 data can be downloaded from METER data loggers using either ZENTRA Utility or ZENTRA Cloud. Refer to the logger user manual for more information about these programs.



## 2.2.2 CONNECT TO NON-METER LOGGER

The ATMOS 41 can be purchased for use with non-METER (third party) data loggers. Refer to the third-party logger manual for details on logger communications, power supply, and ground ports. The [ATMOS 41 Integrator Guide](#) also provides detailed instructions on connecting sensors to non-METER loggers.

ATMOS 41 sensors can be ordered with stripped and tinned (pigtail) wires for use with screw terminals. Refer to the third-party logger manual for details on wiring.

Connect the ATMOS 41 wires to the data logger as illustrated in [Figure 2](#) and [Figure 3](#), with the power supply wire (brown) connected to the excitation, the digital out wire (orange) to a digital input, and the bare ground wire to ground.

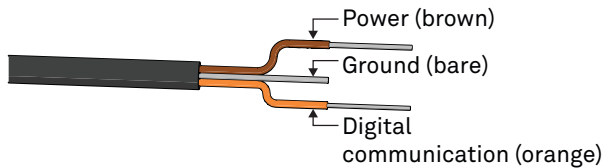

Figure 2 Pigtail wiring

**NOTE:** Some early ATMOS 41 units may have the older Decagon wiring scheme where the power supply is white, the digital out is red, and the bare wire is ground.

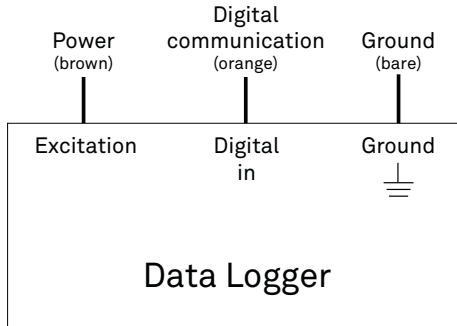

Figure 3 Wiring diagram

**NOTE:** The acceptable range of excitation voltages is from 3.6 to 15.0 VDC. To read the ATMOS 41 with Campbell Scientific data loggers, power the sensors off a 12-V port.

If the ATMOS 41 cable has a standard stereo plug connector and needs to be connected to a non-METER data logger, use one of the following two options.

### Option 1

1. Clip off the stereo plug connector on the sensor cable.
2. Strip and tin the wires.
3. Wire it directly into the data logger.

This option has the advantage of creating a direct connection and minimizes the chance of the sensor becoming unplugged. However, it then cannot be easily used in the future with a METER readout unit or data logger.

### Option 2

Obtain an adapter cable from METER.

The adapter cable has a connector for the stereo plug connector on one end and three wires (or pigtail adapter) for connection to a data logger on the other end. The stripped and tinned adapter cable wires have the same termination as in [Figure 3](#): the brown wire is excitation, the orange is output, and the bare wire is ground.

**NOTE:** Secure the stereo plug connector to the pigtail adapter connections using adhesive-lined heat shrink to ensure the sensor does not become disconnected during use.

## 2.3 COMMUNICATION

The ATMOS 41 communicates using SDI-12 communication protocol. To obtain detailed instructions, refer to the [ATMOS 41 Integrator Guide](#).

The SDI-12 protocol requires that all sensors have a unique address. ATMOS 41 sensor factory default is an SDI-12 address of 0. To add more than one SDI-12 sensor to a bus, the sensor address must be changed as described in these steps.

1. Using a PROCHECK connected to the sensor, press the **MENU** button to bring up the Configuration tab.

**NOTE:** If the PROCHECK does not have this option, please upgrade its firmware to the latest version from the [METER Legacy Handheld Devices](#) webpage.

2. Scroll down to SDI-12 Address. Press **ENTER**.
3. Press the **UP** or **DOWN** arrows until the desired address is highlighted.  
Address options include 0...9, A...Z, and a...z.
4. Press **ENTER**.

Detailed information can also be found in the application note [Setting SDI-12 addresses on METER digital sensors using Campbell Scientific data loggers and LoggerNet](#) ([metergroup.com/environment/articles/setting-addresses-using-campbell-scientific-data-loggers/](http://metergroup.com/environment/articles/setting-addresses-using-campbell-scientific-data-loggers/)).

When using the sensor as part of an SDI-12 bus, excite the sensors continuously to avoid issues with initial sensor startup interfering with the SDI-12 communications.

### 3. SYSTEM

This section describes the ATMOS 41 All-in-One Weather Station system.

#### 3.1 SPECIFICATIONS

##### MEASUREMENT SPECIFICATIONS

Solar Radiation	
Range	0–1750 W/m <sup>2</sup>
Resolution	1 W/m <sup>2</sup>
Accuracy	±5% of measurement typical
Precipitation	
Range	0–400 mm/h
Resolution	0.017 mm
Accuracy	±5% of measurement from 0 to 50 mm/h
Vapor Pressure	
Range	0–47 kPa
Resolution	0.01 kPa
Accuracy	Varies with temperature and humidity, ±0.2 kPa typical below 40 °C

100%	± 0.05	± 0.09	± 0.16	± 0.29	± 0.49	± 0.81	± 1.30	± 2.62	± 6.32
95%	± 0.05	± 0.09	± 0.14	± 0.24	± 0.41	± 0.68	± 1.08	± 2.26	± 5.27
90%	± 0.05	± 0.07	± 0.09	± 0.15	± 0.33	± 0.54	± 1.06	± 2.23	± 5.20
85%	± 0.05	± 0.07	± 0.08	± 0.15	± 0.33	± 0.53	± 1.05	± 2.19	± 5.13
80%	± 0.04	± 0.07	± 0.08	± 0.15	± 0.32	± 0.53	± 0.83	± 1.84	± 4.07
75%	± 0.04	± 0.07	± 0.08	± 0.14	± 0.31	± 0.52	± 0.82	± 1.80	± 4.00
70%	± 0.04	± 0.07	± 0.08	± 0.14	± 0.31	± 0.51	± 0.81	± 1.77	± 3.93
65%	± 0.04	± 0.07	± 0.08	± 0.13	± 0.30	± 0.50	± 0.79	± 1.73	± 3.86
60%	± 0.04	± 0.05	± 0.07	± 0.13	± 0.22	± 0.36	± 0.57	± 1.38	± 3.30
55%	± 0.04	± 0.04	± 0.07	± 0.13	± 0.22	± 0.35	± 0.56	± 1.34	± 3.23
50%	± 0.03	± 0.04	± 0.07	± 0.12	± 0.21	± 0.34	± 0.55	± 1.31	± 3.16
45%	± 0.03	± 0.04	± 0.07	± 0.12	± 0.20	± 0.33	± 0.53	± 1.27	± 2.60
40%	± 0.03	± 0.03	± 0.07	± 0.12	± 0.20	± 0.33	± 0.52	± 1.24	± 2.53
35%	± 0.03	± 0.05	± 0.06	± 0.11	± 0.19	± 0.32	± 0.50	± 1.20	± 2.46
30%	± 0.03	± 0.05	± 0.06	± 0.11	± 0.19	± 0.31	± 0.49	± 1.17	± 2.39
25%	± 0.03	± 0.04	± 0.06	± 0.10	± 0.18	± 0.30	± 0.48	± 1.14	± 2.32
20%	± 0.03	± 0.06	± 0.06	± 0.10	± 0.25	± 0.41	± 0.67	± 1.10	± 2.25
15%	± 0.03	± 0.05	± 0.05	± 0.10	± 0.24	± 0.40	± 0.85	± 1.39	± 2.67
10%	± 0.05	± 0.07	± 0.08	± 0.14	± 0.31	± 0.52	± 0.84	± 1.67	± 4.08
5%	± 0.05	± 0.10	± 0.12	± 0.22	± 0.38	± 0.64	± 1.03	± 1.96	± 5.00
0%	± 0.08	± 0.15	± 0.12	± 0.22	± 0.45	± 0.75	± 1.22	± 3.21	± 5.92
	0°C	10°C	20°C	30°C	40°C	50°C	60°C	70°C	80°C

Figure 4 Vapor pressure sensor accuracy

## SYSTEM

Relative Humidity	
Range	0–100% RH
Resolution	0.1% RH
Accuracy	Varies with temperature and humidity, $\pm 3\%$ RH typical

HUMIDITY (%RH)	100%	$\pm 5\%$	$\pm 5\%$	$\pm 5\%$	$\pm 5\%$	$\pm 5\%$	$\pm 5\%$	$\pm 5\%$	$\pm 6\%$	$\pm 10\%$
	95%	$\pm 5\%$	$\pm 5\%$	$\pm 4\%$	$\pm 4\%$	$\pm 4\%$	$\pm 4\%$	$\pm 4\%$	$\pm 5\%$	$\pm 8\%$
	90%	$\pm 5\%$	$\pm 4\%$	$\pm 2\%$	$\pm 2\%$	$\pm 3\%$	$\pm 3\%$	$\pm 4\%$	$\pm 5\%$	$\pm 8\%$
	85%	$\pm 5\%$	$\pm 4\%$	$\pm 2\%$	$\pm 2\%$	$\pm 3\%$	$\pm 3\%$	$\pm 4\%$	$\pm 5\%$	$\pm 8\%$
	80%	$\pm 4\%$	$\pm 4\%$	$\pm 2\%$	$\pm 2\%$	$\pm 3\%$	$\pm 3\%$	$\pm 3\%$	$\pm 4\%$	$\pm 6\%$
	75%	$\pm 4\%$	$\pm 4\%$	$\pm 2\%$	$\pm 2\%$	$\pm 3\%$	$\pm 3\%$	$\pm 3\%$	$\pm 4\%$	$\pm 6\%$
	70%	$\pm 4\%$	$\pm 4\%$	$\pm 2\%$	$\pm 2\%$	$\pm 3\%$	$\pm 3\%$	$\pm 3\%$	$\pm 4\%$	$\pm 6\%$
	65%	$\pm 4\%$	$\pm 4\%$	$\pm 2\%$	$\pm 2\%$	$\pm 3\%$	$\pm 3\%$	$\pm 3\%$	$\pm 4\%$	$\pm 6\%$
	60%	$\pm 4\%$	$\pm 3\%$	$\pm 2\%$	$\pm 2\%$	$\pm 2\%$	$\pm 2\%$	$\pm 2\%$	$\pm 3\%$	$\pm 5\%$
	55%	$\pm 4\%$	$\pm 2\%$	$\pm 2\%$	$\pm 2\%$	$\pm 2\%$	$\pm 2\%$	$\pm 2\%$	$\pm 3\%$	$\pm 5\%$
	50%	$\pm 4\%$	$\pm 2\%$	$\pm 2\%$	$\pm 2\%$	$\pm 2\%$	$\pm 2\%$	$\pm 2\%$	$\pm 3\%$	$\pm 5\%$
	45%	$\pm 4\%$	$\pm 2\%$	$\pm 2\%$	$\pm 2\%$	$\pm 2\%$	$\pm 2\%$	$\pm 2\%$	$\pm 3\%$	$\pm 4\%$
	40%	$\pm 4\%$	$\pm 2\%$	$\pm 2\%$	$\pm 2\%$	$\pm 2\%$	$\pm 2\%$	$\pm 2\%$	$\pm 3\%$	$\pm 4\%$
35%	$\pm 4\%$	$\pm 3\%$	$\pm 2\%$	$\pm 2\%$	$\pm 2\%$	$\pm 2\%$	$\pm 2\%$	$\pm 3\%$	$\pm 4\%$	
30%	$\pm 4\%$	$\pm 3\%$	$\pm 2\%$	$\pm 2\%$	$\pm 2\%$	$\pm 2\%$	$\pm 2\%$	$\pm 3\%$	$\pm 4\%$	
25%	$\pm 4\%$	$\pm 3\%$	$\pm 2\%$	$\pm 2\%$	$\pm 2\%$	$\pm 2\%$	$\pm 2\%$	$\pm 3\%$	$\pm 4\%$	
20%	$\pm 4\%$	$\pm 4\%$	$\pm 2\%$	$\pm 2\%$	$\pm 3\%$	$\pm 3\%$	$\pm 3\%$	$\pm 3\%$	$\pm 4\%$	
15%	$\pm 5\%$	$\pm 4\%$	$\pm 2\%$	$\pm 2\%$	$\pm 3\%$	$\pm 3\%$	$\pm 4\%$	$\pm 4\%$	$\pm 5\%$	
10%	$\pm 8\%$	$\pm 5\%$	$\pm 3\%$	$\pm 3\%$	$\pm 4\%$	$\pm 4\%$	$\pm 4\%$	$\pm 5\%$	$\pm 8\%$	
5%	$\pm 8\%$	$\pm 8\%$	$\pm 5\%$	$\pm 5\%$	$\pm 5\%$	$\pm 5\%$	$\pm 5\%$	$\pm 6\%$	$\pm 10\%$	
0%	$\pm 12\%$	$\pm 12\%$	$\pm 5\%$	$\pm 5\%$	$\pm 6\%$	$\pm 6\%$	$\pm 6\%$	$\pm 10\%$	$\pm 12\%$	
	0°C	10°C	20°C	30°C	40°C	50°C	60°C	70°C	80°C	
	TEMPERATURE (°C)									

Figure 5 RH sensor accuracy

Air Temperature	
Range	–50 to 60 °C
Resolution	0.1 °C
Accuracy	$\pm 0.6$ °C

Humidity Sensor Temperature	
Range	–40 to 50 °C
Resolution	0.1 °C
Accuracy	$\pm 1.0$ °C

Barometric Pressure	
Range	50–110 kPa
Resolution	0.01 kPa
Accuracy	$\pm 0.1$ kPa from –10 to 50 °C $\pm 0.5$ kPa from –40 to 60 °C

**Horizontal Wind Speed**

Range	0–30 m/s
Resolution	0.01 m/s
Accuracy	The greater of 0.3 m/s or 3% of measurement

**Wind Gust**

Range	0–30 m/s
Resolution	0.01 m/s
Accuracy	The greater of 0.3 m/s or 3% of measurement

**Wind Direction**

Range	0°–359°
Resolution	1°
Accuracy	±5°

**Tilt**

Range	–90° to 90°
Resolution	0.1°
Accuracy	±1°

**Lightning Strike**

Range	0–65,535 strikes
Resolution	1 strike
Accuracy	Variable with distance, >25% detection at <10 km typical

**Lightning Average Distance**

Range	0–40 km
Resolution	3 km
Accuracy	Variable

## COMMUNICATION SPECIFICATIONS

### Output

SDI-12 communication

### Data Logger Compatibility

METER ZL6 and EM60 data loggers or any data acquisition systems capable of switched 3.6- to 15.0-VDC excitation and SDI-12 communication

## PHYSICAL CHARACTERISTICS

### Dimensions

Diameter 10 cm (3.94 in)

Height 34 cm (13.39 in), includes rain gauge filter

### Operating Temperature Range

Minimum -50 °C

Typical NA

Maximum 60 °C

**NOTE:** Barometric pressure and relative humidity sensors operate accurately at a minimum of -40 °C.

### Cable Length

5 m (standard)

75 m (maximum custom cable length for additional cost)

**NOTE:** Contact [Customer Support](#) if a nonstandard cable length is needed.

### Connector Types

3.5-mm stereo plug connector or stripped and tinned wires

## ELECTRICAL AND TIMING CHARACTERISTICS

### Supply Voltage (VCC to GND)

Minimum 3.6 VDC continuous

Typical NA

Maximum 15.0 VDC continuous

**NOTE:** The ATMOS 41 must be continuously powered to work properly.

**NOTE:** For the ATMOS 41 to meet digital logic levels specified by SDI-12, it must be excited at 3.9 VDC or greater.

**Digital Input Voltage (logic high)**

Minimum	2.8 V
Typical	3.0 V
Maximum	5.5 V

**Digital Input Voltage (logic low)**

Minimum	-0.3 V
Typical	0.0 V
Maximum	0.8 V

**Digital Output Voltage (logic high)**

Minimum	NA
Typical	3.6 V
Maximum	NA

**NOTE:** For the ATMOS 41 to meet digital logic levels specified by SDI-12, it must be excited at 3.9 VDC or greater.

**Power Line Slew Rate**

Minimum	1.0 V/ms
Typical	NA
Maximum	NA

**Current Drain (during measurement)**

Minimum	0.2 mA
Typical	8.0 mA
Maximum	33.0 mA

**Current Drain (while asleep)**

Minimum	0.2 mA
Typical	0.3 mA
Maximum	0.4 mA

**Power Up Time (SDI ready)—aRx! Commands**

Minimum	NA
Typical	10 s
Maximum	NA

**Power Up Time (SDI ready)—Other Commands**

Minimum	NA
Typical	800 ms
Maximum	NA

**Measurement Duration**

Minimum	NA
Typical	110 ms
Maximum	3,000 ms

**COMPLIANCE**

Manufactured under ISO 9001:2015
EM ISO/IEC 17050:2010 (CE Mark)

**3.2 PYRANOMETER**

Solar radiation is measured by a pyranometer that is integrated into the lip of the rain gauge funnel at the top of the ATMOS 41. Designed, manufactured, and calibrated by experts at Apogee Instruments, the miniature pyranometer uses a silicon-cell sensor to measure the total incoming (direct and diffuse) solar radiation. A carefully developed cosine-correcting head ensures accurate readings regardless of sun angle, while the painstakingly researched optical filter material balances cost and performance to ensure the silicon-cell provides good accuracy regardless of temperature or sensor age. Silicon-cell sensors have excellent response time to changing radiation conditions and acceptable sensitivity across the solar spectrum (Figure 6), which make them perfect for use on the ATMOS 41.

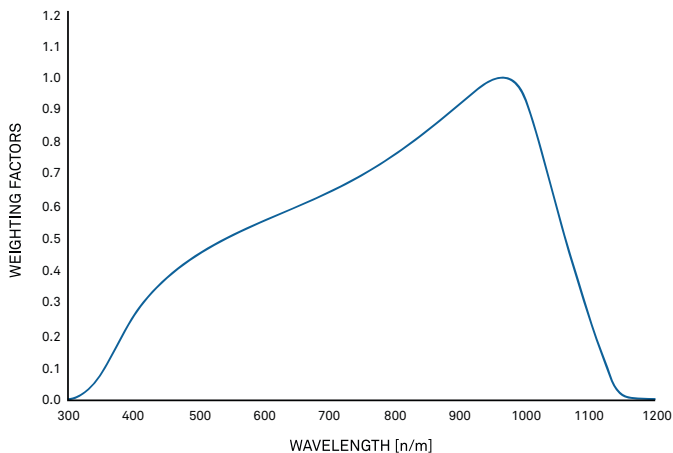

**Figure 6** Spectral response estimate of Apogee silicon-cell pyranometers



Spectral response was estimated by multiplying the spectral response of the photodiode, diffuser, and adhesive. Spectral response measurements of diffuser and adhesive were made with a spectrometer, and spectral response data for the photodiode were obtained from the manufacturer.

Leveling the ATMOS 41 is particularly important for accurate solar radiation measurements. Out of level, the pyranometer will overestimate some portions of the day while underestimating others. Ensure accurate solar radiation measurements by carefully leveling the ATMOS 41 at installation. Bird droppings and other soiling of the domed sensor surface will cause serious errors in pyranometer measurements. Check the sensor regularly to make sure it is clean and check data often to identify possible problems. Isopropyl (rubbing) alcohol and a Q-tip work well for cleaning the sensor area. Microfiber bags work well, too. Do NOT use an abrasive cloth on the sensor surface, as it will scratch.

The pyranometer is factory calibrated and the sensor-specific calibration value can be found on the interior of the rain funnel. This factor has already been added into the ATMOS 41 so there is no need to do anything with it. In the event that this value is needed, it can be found by taking the funnel off the base and checking underneath. Follow the steps in [Section 3.5](#) to remove the funnel.

When powered on, the ATMOS 41 measures the solar radiation once every 10 s and records the instantaneous values. When queried, the ATMOS 41 outputs the average of the instantaneous measurements since the last query.

### 3.3 ANEMOMETER

The space underneath the rain gauge is where the ATMOS 41 measures wind speed. Ultrasonic signals emitted from transducers at right angles to each other bounce off the porous sintered glass plate ([Figure 7](#)) and back up to the opposite sensor. The speed of sound is affected by the wind, and the wind speed is calculated by measuring differences in the time it takes for sound to travel back and forth between sensors ([Section 3.10.1](#)).

When powered on, the ATMOS 41 measures the wind speed and direction once every 10 s and records the instantaneous wind vector components. When queried, the ATMOS 41 outputs the average of the instantaneous measurements since the last query for wind speed and direction and the maximum instantaneous wind speed value for wind gust.

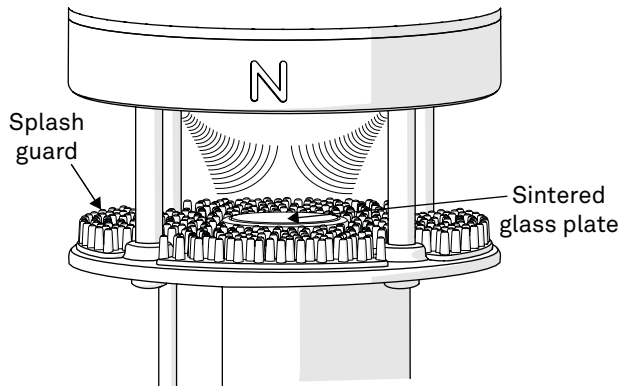

Figure 7 Anemometer

The ATMOS 41 measures wind speed every 10 s and keeps a running average of the last 10 measurements. If an instantaneous measurement is more than eight times the running average, the instantaneous measurement is rejected. It is not reported as the maximum gust or included in the data that are averaged over the output interval.

For normal ATMOS 41 use cases, this is an effective method for eliminating inaccuracy resulting from spurious spikes in wind speed (e.g., bumblebee checking out the ultrasonic path). In special use cases where data are output frequently and large step changes in wind speed are present (e.g., turning on a wind tunnel), this spike rejection algorithm may result in an error code being output.

### 3.4 VAPOR PRESSURE/RELATIVE HUMIDITY SENSOR

The vapor pressure sensor (Figure 8) on the ATMOS 41 is located behind the circular Teflon® screen in the same housing as the sonic transducers. The Teflon screen protects the sensor from liquid water and dust while allowing water vapor to freely pass to the sensor and equilibrate with air vapor pressure. The sensor measures relative humidity and temperature in addition to computing vapor pressure.

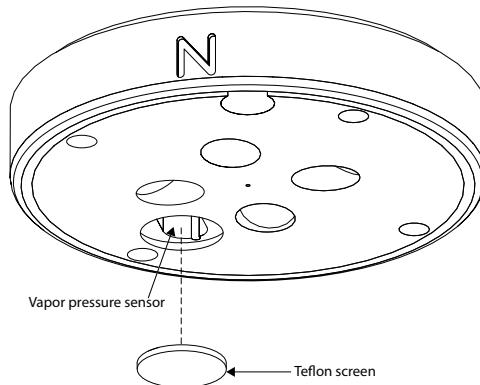

Figure 8 Vapor pressure sensor

If the relative humidity of the air is desired, it can be computed using Equation 1.

$$RH_{r,air} = \frac{e_a}{e_s(T_{air})} \quad \text{Equation 1}$$

where  $e_a$  is the vapor pressure of the air, from the ATMOS 41, and  $e_s(T_{air})$  is saturation vapor pressure at the air temperature given by the ATMOS 41.

The saturation vapor pressure is calculated using the Magnus-Tetens equation (Equation 2) with the following coefficients described by Buck (1981).

$$e_s T_{air} = a \exp\left(\frac{b T_{air}}{c + T_{air}}\right) \quad \text{Equation 2}$$

<b>Water</b>	$a = 0.611 \text{ kPa}$	$b = 17.502$	$c = 240.97 \text{ }^\circ\text{C}$	$T_{air}$ = Temperature in $^\circ\text{C}$
<b>Ice</b>	$a = 0.611 \text{ kPa}$	$b = 21.87$	$c = 265.5 \text{ }^\circ\text{C}$	$T_{air}$ = Temperature in $^\circ\text{C}$

Unlike relative humidity, vapor pressure does not depend on temperature, and is generally conservative over time and space. The vapor pressure of the atmosphere near the relative humidity sensor is the same as the vapor pressure at the relative humidity sensor, even if the relative humidity sensor is not at the same temperature as the atmosphere. Additionally, it is the vapor pressure of the atmosphere (not RH) that controls the rate of vapor phase water transport (e.g., evaporation, transpiration, and distribution of water vapor). Therefore, vapor pressure is a much more useful measure of atmospheric moisture than relative humidity.

The METER ZENTRA system calculates and outputs vapor pressure deficit (VPD) in the standard data stream. VPD is simply  $e_s(T_{air}) - e_a$  and gives a good indication of evaporative demand.

When powered on, the ATMOS 41 measures the vapor pressure once every 60 s and records the instantaneous values. When queried, the ATMOS 41 outputs the average of the instantaneous measurements since the last query.

### 3.5 RAIN GAUGE

The ATMOS 41 contains a 9.31-cm diameter rain gauge. During rain events, the flared hole (Figure 9) forms the rain into drops that pass by the drip counter. The spring (Figure 9) acts as a filter to keep out large particles but still allows enough flow so water does not back up. Gold pins (Figure 9) measure each drop of rain. Because the flared hole forms a drop of a known size, the ATMOS 41 counts the drops and calculate the water volume. As the rain intensity increases, the drops become smaller, but the ATMOS 41 firmware contains an algorithm to automatically compensate for drop size as the rain increases.

When powered on, the ATMOS 41 counts water drops continuously and adds each drop to an accumulated total. When queried, the ATMOS 41 outputs the total rainfall (in millimeters) that has accumulated since the last query. Precipitation maximum intensity calculation is capped at 280 mm/h, available from METER data loggers and software.

**IMPORTANT:** The ATMOS 41 must be within approximately  $\pm 2$  degrees of dead level (0, 0) in both the X and Y directions to accurately measure rainfall. If not within this range, drops from the flared hole can miss the gold electrodes entirely.

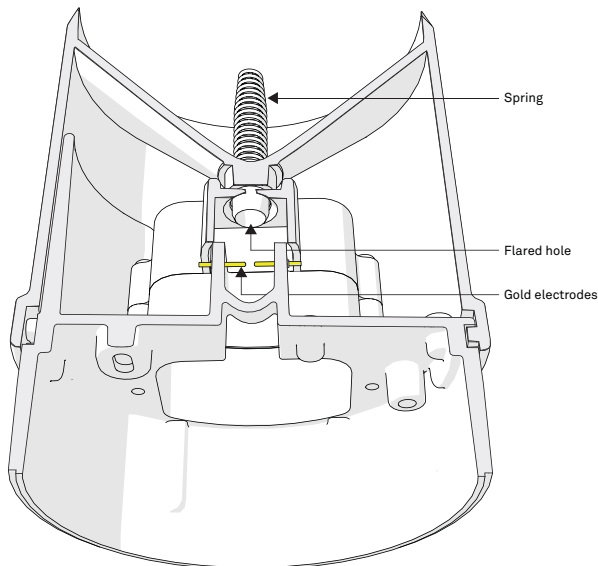

Figure 9 Rain gauge

The rain gauge locks in place using two pegs on the side of the rain gauge funnel. Follow the steps below to get inside the rain gauge.

1. Line up the lock/unlock graphic located on the side of the rain gauge funnel with the notch on the interface plate.
2. Press the rain gauge funnel down against the spring and turn counter clockwise until it clicks in place.

**ATTENTION:** UNPLUG THE PYRANOMETER CONNECTOR INSIDE THE FUNNEL BEFORE FULLY REMOVING THE FUNNEL.

3. Before replacing the cover, be sure to reattach the pyranometer connector by mating the two halves of the white connector and seating firmly together until the tabs lock.

**NOTE:** The connector is polar so it can only mate in one orientation.

4. Check to be sure the downspout screen is in place on the water exit downspout (Figure 14). This keeps bugs out of the interior of the sensor.

### 3.6 TEMPERATURE SENSOR

The ATMOS 41 temperature measurement (Figure 10) is made in the center of the anemometer area where a small stainless steel needle containing a tiny temperature sensor (thermistor) extends from the middle of the four sonic transducers in the center of the anemometer. Unlike most air temperature measurements, the weather station sensor is not covered with louvered plates to protect from solar heating. Instead, it sits in open air, susceptible to solar heating of the instrument body. However, the ATMOS 41 calculates the air temperature accurately because solar radiation and the wind speed are known. These are the two main parameters that determine the error between measured air temperature and the actual air temperature. Therefore, it is possible to solve the energy balance to get what the actual temperature should be based on the solar load of the body and the convective cooling of that temperature sensor.

When powered on, the ATMOS 41 measures the air temperature once every 10 s and records the instantaneous values. When queried, the ATMOS 41 outputs the average of the instantaneous measurements since the last query.

**NOTE:** The ATMOS 41 body and especially the temperature sensor should not be painted or coated.

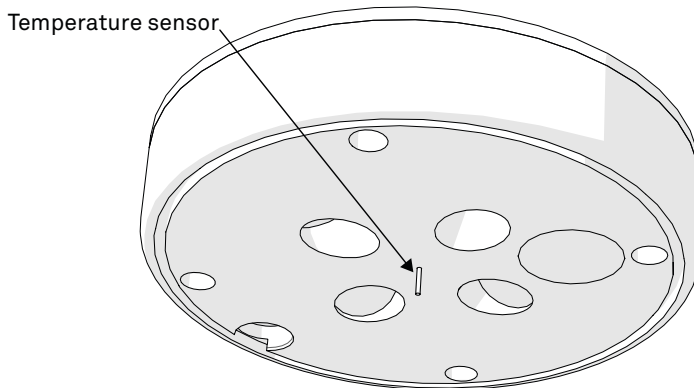

Figure 10 Temperature sensor

### 3.7 LIGHTNING SENSOR

The lightning sensor acts much like an AM radio. During a thunderstorm, the crack of the lightning disrupts the AM signal. The integrated circuit inside the sensor listens for this disturbance and registers the time of and distance (intensity of signal) to the strike. The sensor outputs the total number of strikes and average distance to these strikes in the measurement period. When powered on, the ATMOS 41 counts lightning events continuously and adds each detected event to an accumulated total. When queried, the ATMOS 41 outputs the total number of lightning events that have been detected since the last query.

The sensitivity of the lightning sensor can be adjusted using the PROCHECK.

To set the Strike Reject Lvl follow the steps below:

1. Plug the weather station stereo connector into the PROCHECK stereo port.
2. Press **MENU** to navigate to the Configuration tab
3. Scroll down to ATMOS 41 Config. Press **ENTER**.
4. Press **ENTER** to select Strike Reject Lvl.



Figure 11 ATMOS 41 configuration screen using PROCHECK

The Strike Reject Lvl adjusts the lightning sensor threshold used to differentiate between man-made electrical noise and lightning strikes. The higher the value, the less likely man-made electrical noise will cause a false lightning strike, but the more likely lightning strike events from far away will be filtered out and missed.

5. Press the **UP** and **DOWN** arrows to select a value between 0 and 15.  
The default value is 5. Generally, a small deviation of 1 or 2 from the default value is sufficient to tune the level to the installation environment.
6. Press **ENTER** or **SAVE** to save the new Strike Reject Lvl to the sensor.

### 3.8 BAROMETRIC PRESSURE SENSOR

The barometric pressure sensor is located behind the Teflon screen next to the relative humidity sensor. It measures the atmospheric pressure of the environment in which the ATMOS 41 is deployed. With a range from 50 to 110 kPa, it is suitable for measurement across a wide range of elevations, but keep in mind that the magnitude of sensor output will depend chiefly on the installation altitude with subtle changes caused by weather.

When powered on, the ATMOS 41 measures the barometric pressure once every 60 s and records the instantaneous values. When queried, the ATMOS 41 outputs the average of the instantaneous measurements since the last query.

### 3.9 TILT SENSOR

The ATMOS 41 is also equipped with a tilt sensor similar to those found in smartphones. The primary use of the tilt sensor data is to ensure the ATMOS 41 remains level at all times. Regularly check X and Y tilt data to ensure the ATMOS 41 is level; if it has tilted, return to the site and level again. Even a slightly off-level ATMOS 41 will cause errors in the solar radiation measurement, and a 2° tilt can cause large errors in the rainfall measurement. Although this sensor may be used to level the instrument, it is much easier to use the small bubble level on the bottom of the anemometer plate. For reference, a positive X tilt indicates that the ATMOS 41 is leaning north, and a positive Y tilt indicates that the ATMOS 41 is leaning west.

When powered on, the ATMOS 41 measures the tilt in the X and Y orientation once every 60 s and records the instantaneous values. When queried, the ATMOS 41 outputs the average of the instantaneous measurements since the last query.

### 3.10 THEORY

The following sections explain the theory of wind speed, wind direction, and air temperature measurements.

#### 3.10.1 WIND SPEED AND DIRECTION

The theory behind the anemometer comes from Campbell and Unsworth (1979). The speed  $c$  (m/s) of sound in still air depends on air temperature  $T$  (K), vapor pressure  $e$  (kPa), and atmospheric pressure,  $p$  (kPa), as shown in [Equation 3](#).

$$c = 20.067 \sqrt{T \left( 1 + \frac{0.32e}{p} \right)}$$
Equation 3

For a given sound path length,  $d$  (m), the number of wavelengths,  $n$ , in still air is determined with [Equation 4](#).

$$n = \frac{vd}{c}$$
Equation 4

## SYSTEM

Here  $\nu$  is the frequency of the sound (Hz). When the air is moving, the speed of sound is the sum of the wind speed and the speed of sound in still air. The anemometer transmits a sound pulse in a forward direction, then a similar pulse in the reverse direction. The difference in  $n$  between the two points is computed. If the vector magnitude of the wind in the direction of the sound is  $u$  (m/s), then

$$n - \Delta n_+ = \frac{\nu d}{c + u} \quad \text{Equation 5}$$

$$n - \Delta n_- = \frac{\nu d}{c - u} \quad \text{Equation 6}$$

for sound traveling with and against the wind. Subtracting the result of [Equation 5](#) from the results of [Equation 6](#) creates [Equation 7](#).

$$\Delta n = \Delta n_+ - \Delta n_- = \frac{2\nu d u}{c^2 - u^2} \quad \text{Equation 7}$$

Even at the maximum wind speeds for the anemometer,  $u^2$  is only about 1% of  $c^2$ , so the equation can be simplified as shown in [Equation 8](#).

$$x \cong \frac{c^2}{2\nu d} \Delta n \quad \text{Equation 8}$$

This is the basic equation for the anemometer. Delta ( $\Delta$ )  $n$  is proportional to the phase difference between the forward and reverse sound pulses. The sound comes from a 40 kHz ultrasonic transducer in the head of the anemometer. A sound pulse is transmitted diagonally across the anemometer, bouncing off a sintered glass plate in the center. The sound pulse is then received by another transducer in the anemometer head that is opposite the first. Once the sound pulse is received, the receiver becomes the transmitter and the process is repeated. Two more sensors, mounted at 90 degrees from the first two, give the other horizontal component of the wind. The sound travels a total distance of about 72 mm from transmitter to receiver, but  $d$  in the equations is just the horizontal distance, which is 40 mm.

If  $u$  is the magnitude of the wind vector in the east-west direction (east +) and  $\nu$  is the magnitude in the north-south direction (north +), then wind speed is computed with [Equation 9](#).

$$S = \sqrt{\bar{u}^2 + \bar{\nu}^2} \quad \text{Equation 9}$$

Where the overbar indicates an average of the values sampled every 10 s, wind direction is computed with [Equation 10](#).

$$\theta = \tan^{-1}(\bar{\nu} / \bar{u}) \quad \text{Equation 10}$$



The wind measurement through more frequent SDI-12 commands requires 42 ms to complete. An additional 60 ms are required for the computations to determine phase differences. The anemometer samples every 10 s (or more often if requested). The gust speed reported is the highest instantaneous wind speed measured during the selected averaging interval (must be >20 s or gusts will equal speed).

The ATMOS 41 uses a wind speed spike rejection scheme to protect against the inclusion of spurious wind speed spikes in the averaged wind speed data. The ATMOS 41 measures wind speed every 10 s and keeps a running average of the last 10 measurements. If an instantaneous measurement is more than eight times the running average, then the instantaneous measurement is rejected and not reported as the maximum gust or included in the data that are averaged over the output interval.

For normal ATMOS 41 use cases, this is an effective method for eliminating inaccuracy resulting from spurious spikes in wind speed (e.g., bumblebee investigating the ultrasonic path). In special use cases where data are output frequently and large step changes in wind speed are present (e.g., turning on a wind tunnel), this spike rejection algorithm may result in an error code being output.

**NOTE:** Cup anemometers average over a much longer interval than 42 ms, so the gusts measured with a sonic anemometer will have a larger peak-to-mean ratio than one would see with a cup anemometer.

### 3.10.2 TEMPERATURE

The ATMOS 41 uses an energy balance correction to adjust measured temperature to actual air temperature according to [Equation 11](#).

$$T_{corr} = T_{uncorr} - \left( \frac{\alpha_s S_t}{c_p k \sqrt{u/d}} \right) \quad \text{Equation 11}$$

where:

- $\alpha_s$  = the absorptivity of the surface to solar radiation
- $S_t$  = the total solar radiation measured
- $c_p$  = 29.3 J mol<sup>-1</sup> C<sup>-1</sup>, k is a constant
- $u$  = the wind speed
- $d$  = the characteristic dimension

Although these values can be assumed, some ( $\alpha_s$  and  $k$ ) were optimized using a Levenberg Marquardt Least Squares analysis. Optimal air temperature was obtained using an Apogee TS-100 Aspirated Radiation Shield. Data were collected over several weeks and final values are shown in [Table 2](#).

**NOTE:** A maximum value optimization for  $S_t$  was added because radiation values higher than that cause the corrected temperature to deviate from actual values more than when a maximum  $S_t$  was used.

Table 2 Optimized values for air temperature correction

$a_s$	$d$ (m)	$k$	$c_p$ (J mol <sup>-1</sup> K <sup>-1</sup> )	Max $S_i$ (W/m <sup>2</sup> )
0.295	0.00083	0.0984	29.3	352.3

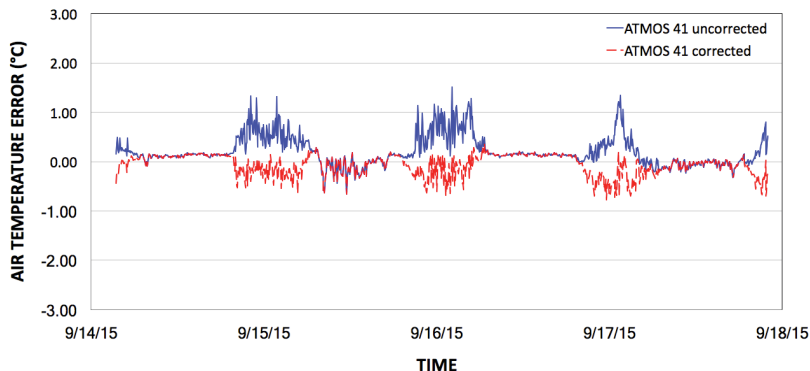

Figure 12 Corrected air temperature comparison with the aspirated radiation shield using 1-min measurement intervals

Figure 12 shows the results from the temperature correction compared to the aspirated temperature, which shows data sampled at 1 min and not averaged over time. The estimated accuracy of the air temperature measurement, based on two standard deviations (95% confidence interval), is 0.42 °C. To provide an idea of how comparable the data are, a concurrently tested temperature sensor in a radiation shield (typical measurement approach) showed an accuracy of 0.66 °C, also based on a two-standard deviation estimate. Thus, the temperature correction of the ATMOS 41 appears to give a better estimate of actual air temperature than the generally accepted radiation shield technique.

NOTE: Without correction, the accuracy of the temperature measurement is  $\pm 2$  °C.

## 3.11 LIMITATIONS

The ATMOS 41 is engineered to be a robust device with minimal downtime. However, it does have limitations that will affect its measurements under some conditions.

### 3.11.1 SNOW AND ICE ACCUMULATION

The ATMOS 41 is not heated, so it will not measure frozen precipitation until snow and ice that have accumulated in the funnel melt. In locations with heavy snowfall or long periods below freezing, it is almost certain that snow accumulation will fill the funnel and no longer accumulate, leading to inaccurate precipitation measurements even when the precipitation melts. Accumulation of snow, ice, or frost will also adversely affect the accuracy of the solar radiation measurement and can compromise the wind measurements if accumulation occurs in the anemometer acoustic pathway or on the acoustic mirror (Section 4.3). See

the app note [How does the ATMOS 41 perform under below freezing and snowy conditions](http://metergroup.com/atmos-41-perform-under-below-freezing-and-snowy-conditions) (metergroup.com/atmos-41-perform-under-below-freezing-and-snowy-conditions) for more information on ATMOS 41 performance in high-latitude winter.

### 3.11.2 HEAVY RAIN AND STRONG WIND

During strong storm events, water can splash off of the horizontal bottom plate of the anemometer envelope and interrupt the signal passing between the sonic transducers. The spikes on the bottom plate help dissipate the energy of rainwater to minimize splashing and reduce the likelihood that the wind measurements are interrupted. Additionally, specially treated hydrophobic porous polyethylene membranes protect the ultrasonic transducers from direct splashing and the sintered (porous) glass construction draws water from the upper surface of the acoustic mirror to keep a constant sound path length. Despite these features heavy rain and strong wind can still cause water to reach the membranes and also cause temporary water buildup on the acoustic mirror. The hydrophobic nature of the transducer protective membranes and the quick-draining ability of the acoustic mirror should limit wind measurement interruptions to heavy rain events and should bring wind measurement back online soon after extreme conditions abate.

### 3.11.3 ELECTROMAGNETIC INTERFERENCE

ATMOS 41 lightning and rainfall measurements can be adversely affected by high level Electromagnetic Interference (EMI), such as that produced by high voltage power transmission lines. Be sure to locate the ATMOS 41 far from such sources of EMI.

## 3.12 MEASUREMENTS WITH METER LOGGERS

METER EM60G and ZENTRA series data loggers query the ATMOS 41 once every minute and record the appropriate accumulations, averages, and maximums from the ATMOS 41 in memory. When the measurement interval is reached, the 1-min measurements are processed into the appropriate accumulations, averages, and maximums and output to final storage (see the logger manual for more information). [Table 3](#) describes the quantities output from the ATMOS 41 and how they are processed in the logger for each ATMOS 41 measurement.

**Table 3 ATMOS 41 output quantities processed in METER data logger**

Measurement	Data Output Every Minute	Data Saved by Logger Each Measurement Interval ( <i>m</i> = number of minutes)
Solar radiation	Average of six 10-s solar radiation measurements	Average of <i>m</i> 1-min averages of solar radiation
Wind speed	Average of six 10-s wind speed measurements in both horizontal wind vectors	Wind run is calculated from each 1-min average of both horizontal wind vectors. METER logger saves average wind run from <i>m</i> 1-min averages.

Table 3 ATMOS 41 output quantities processed in data logger (continued)

Measurement	Data Output Every Minute	Data Saved by Logger Each Measurement Interval ( $m$ = number of minutes)
Wind direction	Average of six 10-s wind speed measurements in both horizontal wind vectors	Weighted direction calculated from horizontal wind vectors
Wind gust	Maximum of six 10-s wind speed measurements	Maximum wind gust recorded over measurement interval
Vapor pressure	Instantaneous measurement of vapor pressure	Average of $m$ instantaneous vapor pressure measurements
Rainfall	Rainfall accumulation over 1-min period	Accumulation of rainfall over $m$ 1-min periods
Maximum rainfall rate	Rainfall accumulation over 1-min period	Maximum rainfall accumulation recorded for a single 1-min period multiplied by 60 min/h
Air temperature	Average of six 10-s air temperature measurements	Average of $m$ 1-min averages of air temperature
Lightning strikes	Lightning strikes detected of 1-min period	Accumulation of lightning strikes detected over $m$ 1-min periods
Lightning distance	Average distance for all strikes detected over 1-min period	Average of $m$ 1-min averages of lightning distance (yields approximate distance to edge of storm)
Barometric pressure	Instantaneous measurement of barometric pressure	Average of $m$ instantaneous barometric pressure measurements
Tilt	Instantaneous measurements of tilt in X and Y orientation	Average of $m$ instantaneous measurements of tilt in X and Y orientation

## 4. SERVICE

This section contains calibration and recalibration information, calibration frequencies, cleaning and maintenance guidelines, troubleshooting guidelines, customer support contact information, and terms and conditions.

### 4.1 CALIBRATION

- **Solar Radiation:** ATMOS 41 pyranometers are calibrated through side-by-side comparison to the mean of four Apogee model SP-110 transfer standard pyranometers (shortwave radiation reference) under high-intensity discharge metal halide lamps. The transfer standard pyranometers are calibrated through side-by-side comparison to the mean of at least two ISO-classified reference pyranometers under sunlight (clear sky conditions) in Logan, Utah. Each of four ISO-classified reference pyranometers are recalibrated on an alternating yearly schedule (two instruments each year) at the National Renewable Energy Laboratory (NREL) in Golden, Colorado. NREL reference standards are calibrated to the World Radiometric Reference (WRR) in Davos, Switzerland.
- **Precipitation:** ATMOS 41 rain gauges do not receive individual calibration. The critical parameter for accurate measurement is drop size (which is controlled by the geometry of the rain gauge nozzle), and the rain gauge nozzle is an injection molded piece with static geometry. The accuracy of each ATMOS 41 rain gauge is verified at a single rainfall rate during the manufacturing and quality assurance (QA) process. A subsample of rain gauges undergoes a more in-depth accuracy verification each month as part of routine QA procedures.
- **Air Temperature:** The air temperature sensor is specified to be accurate to 0.1 °C by the original manufacturer. All sensors are verified against a NIST-traceable standard thermometer at the time of manufacture.
- **RH/Vapor Pressure:** ATMOS 41 relative humidity/vapor pressure sensors receive a three-point calibration using a METER WP4C chilled-mirror dew point sensor as the calibration standard at 20%, 50%, and 80% RH. The WP4C is calibrated every 3 months against four salt standards of known RH (Robinson and Stokes 1970) to be accurate to within 0.2% RH.
- **Barometric Pressure:** Each ATMOS 41 barometric pressure sensor is calibrated against the average of three secondary standard Measurement Specialties MS5611 pressure sensors. The MS5611 sensors are calibrated every 3 months against a GE Druck TERPS 8100-series pressure sensor. The GE pressure sensor is calibrated yearly at certified laboratory with NIST traceability.
- **Wind Speed:** The relationship between wind speed and phase is determined by geometry and the laws of physics. Since the geometry is tightly controlled in manufacture, no individual anemometer calibration is needed. The phase of each ATMOS 41 anemometer is initially set to zero in a zero wind-speed condition. Extensive wind-tunnel and field testing has shown this to result in accurate wind-speed measurements. A subsample of anemometers is checked monthly for accuracy as part of routine QA procedures.

- **Wind Direction:** The ATMOS 41 wind direction measurement depends on the geometry of the ultrasonic transducers and the north orientation indicator on the ATMOS 41 body. This geometry is held to within 0.025-mm specifications through CNC milling procedures. Orientation of the ATMOS 41 toward North will introduce more error in the wind direction measurement than sensor geometry.
- **Sensor Tilt:** The ATMOS 41 tilt sensor is zeroed against the primary bubble level on the bottom side of the upper anemometer housing.
- **Lightning Strike Counter:** Calibration on ATMOS 41 lightning strike detector is performed by the original manufacturer of the lightning detection chip prior to integration into the ATMOS 41. Verification that the lightning strike sensor meets specification is performed on each ATMOS 41 unit during QA procedures.
- **Lightning Distance:** Calibration on ATMOS 41 lightning distance detector is performed by the original manufacturer of the lightning detection chip prior to integration into the ATMOS 41. No further calibration is performed during sensor integration.

## 4.2 RECALIBRATION RECOMMENDATIONS

Table 4 lists the recommended sensor calibration frequencies.

**Table 4 Sensor calibration frequencies**

Sensor Function	Calibration Frequency
Solar radiation	Every 2 years <sup>a</sup>
Barometric pressure	Every 2 years <sup>b</sup>
Relative humidity (RH)	Every 2 years <sup>b</sup>
All other sensors	Not needed

<sup>a</sup> Calibrated, field-swappable replacement pyranometers are available from METER. Contact [Customer Support](#) to purchase a new funnel and consult [Instructions for swapping ATMOS 41 funnel](#) ([metergroup.com/swapping-atmos-41-funnel-pyranometer-sensor](http://metergroup.com/swapping-atmos-41-funnel-pyranometer-sensor)) for instructions on field swapping the pyranometer.

<sup>b</sup> ATMOS 41 barometric pressure and vapor pressure/RH sensors and their respective calibrations are housed on a module that sits behind the circular Teflon membrane in the same housing as the sonic transducers ([Figure 8](#)). This module is field-swappable, so sensors in need of calibration can be removed and replaced by a module with calibrated sensors. Please contact [Customer Support](#) for new sensor modules and consult [Instructions for swapping ATMOS 41 daughterboard](#) ([metergroup.com/swapping-atmos-41-rh-temperature-barometric-pressure-module](http://metergroup.com/swapping-atmos-41-rh-temperature-barometric-pressure-module)) for instructions on swapping the module.

## 4.3 CLEANING AND MAINTENANCE

For more information on thoroughly cleaning the ATMOS 41, see [ATMOS cleaning instructions](#) ([metergroup.com/meter\\_knowledgebase/atmos-41-cleaning-instructions/](http://metergroup.com/meter_knowledgebase/atmos-41-cleaning-instructions/)).

1. Make sure nothing is obscuring the temperature sensor or the sonic transducers shown in [Figure 13](#) (cobwebs, leaves, wasp nests, etc.).
2. Check the following areas to make sure they are clear of miscellaneous environmental, animal (specifically bird droppings) and insect debris, or spider webs:

- a. Rain funnel (Figure 16)
  - b. Pyranometer (Figure 16)
  - c. Ultrasonic transducer openings (Figure 13)
  - d. Sintered glass reflection plate (Figure 7)
3. Clean the ATMOS 41 body.
    - a. Scrub with light to medium pressure using a warm, damp cloth.
    - b. Clean around posts and between crevices using a dry brush.

## CAUTIONS

- **DO NOT** immerse the sensor in water.
- **DO NOT** touch the temperature sensor needle (Figure 13).  
 CAUTION: The temperature sensor needle lead wires are very delicate and can be easily damaged.
- Avoid more than light pressure on the sonic transducers (Figure 13).
- Be sure the sensor is level after cleaning.

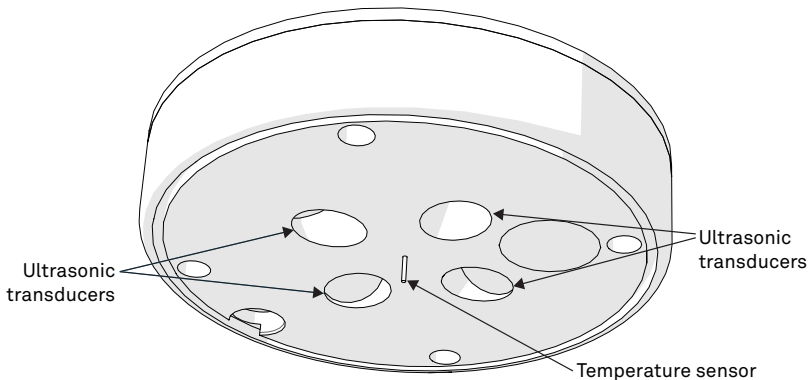

**Figure 13** Temperature needle and ultrasonic transducers

**NOTE:** Do not allow water to enter the ultrasonic sensors (Figure 13). Water may corrode the metal parts inside the sensors and ruin them. Do not touch the temperature sensor when cleaning because it is very delicate and can be damaged if pushed into the ATMOS 41 body.

- c. Check the downspout (Figure 14) for debris.
- d. Observe the Teflon screen (Figure 15) to see if it is dirty.  
 If the screen is dirty, it is best to replace it.

Contact [Customer Support](#) for a replacement Teflon screen.

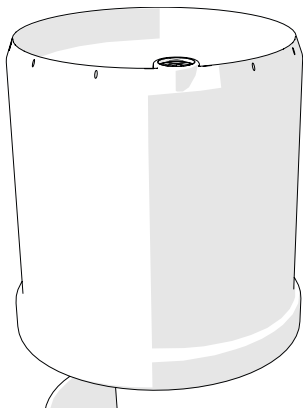

Figure 14 Downspout

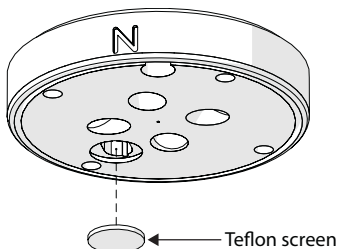

Figure 15 Teflon screen

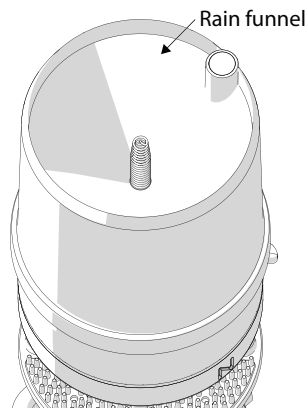

Figure 16 Rain funnel and pyranometer

## 4.4 UPDATE FIRMWARE

METER will occasionally release firmware updates that improve ATMOS 41 performance. Instructions for updating firmware and links to the latest firmware files can be found at the tech note [Instructions for updating ATMOS 41 firmware](https://metergroup.com/environment/articles/updating-atmos-41-firmware/) (metergroup.com/environment/articles/updating-atmos-41-firmware/). Please consult with [Customer Support](#) about any questions about the necessity or process of updating firmware on ATMOS 41.

## 4.5 TROUBLESHOOTING

Table 5 Troubleshooting the ATMOS 41

Problem	Possible Solutions
<p><b>ATMOS 41 not responding</b></p>	<ul style="list-style-type: none"> <li>Check power to the sensor.</li> <li>Check sensor cable and stereo plug connector integrity.</li> <li>Try a different port on the data logger.</li> <li>Check data logger wiring to ensure the following connections:                             <ul style="list-style-type: none"> <li>Brown—3.6- to 15.0-V power supply</li> <li>Orange—digital out</li> <li>Bare—ground</li> </ul> </li> <li>If sensor does not respond, use the PROCHECK to make sure it is working satisfactorily.</li> </ul>



**Table 5 Troubleshooting the ATMOS 41 (continued)**

Problem	Possible Solutions
<p><b>Not reading any rain or not measuring rain accurately</b></p>	<p>Remove any debris from rain gauge funnel. The ATMOS 41 must be within approximately <math>\pm 2</math> degrees of dead level (0, 0) in both the X and Y directions to accurately measure rainfall. If not within this range, drops from the flared hole can miss the gold electrodes entirely. Use the internal level measurements that are available in the ATMOS 41 data stream to confirm that the ATMOS 41 is level.</p> <p>Gently twist the top of the weather station and remove the rain gauge funnel.</p> <p><b>NOTE: BE CAREFUL TO UNPLUG THE PYRANOMETER CONNECTOR INSIDE THE FUNNEL BEFORE REMOVING THE FUNNEL COMPLETELY.</b></p> <p>Check to make sure that there are no obvious problems and that the gold electrodes are aligned correctly <a href="#">Figure 18</a>.</p> <div style="display: flex; justify-content: space-around; align-items: center;"> <div style="text-align: center;">  <p><b>Figure 17 Pyranometer</b></p> </div> <div style="text-align: center;">  <p><b>Figure 18 Gold electrodes</b></p> </div> </div> <p>The accuracy of the rain gauge measurement can be checked using the procedure described in <a href="http://metergroup.com/atmos-41-drip-counter-calibration">How to check the drip counter calibration</a> (metergroup.com/atmos-41-drip-counter-calibration).</p>
<p><b>Water not flowing through rain gauge</b></p>	<p>Check spring, screen, and the outflow to ensure there is no lodged debris.</p>
<p><b>No wind speed</b></p>	<p>Check anemometer pathway to make sure there is no debris blocking the path of the sonic transducer measurement (between transducers and acoustic mirror on base).</p> <p>Check the sonic transducers for water build-up; if there is moisture, take a dry cloth and dab it away.</p> <p>Check to see that the sintered glass plate (<a href="#">Figure 7</a>) is not dirty. Clean by flushing with water and dry with a dry cloth (<a href="#">Section 4.3</a>).</p> <p>Be sure the ATMOS 41 is level.</p>

Table 5 Troubleshooting the ATMOS 41 (continued)

Problem	Possible Solutions
No temperature reading	<p>Check the temperature needle to be sure it is not pushed in (pushing in the temperature sensor will break the thermistor wires and stop measurement).</p> <p>Do not to abuse the temperature sensor needle when cleaning, because its very delicate lead wires can be easily damaged.</p>
No pyranometer reading	<p>Carefully remove the rain funnel as described in <a href="#">Section 3.5</a>.</p> <p><b>NOTE: BE CAREFUL TO UNPLUG THE PYRANOMETER CONNECTOR INSIDE THE FUNNEL BEFORE FULLY REMOVING THE FUNNEL.</b></p> <p>Make sure the pyranometer plug (<a href="#">Figure 17</a>) is plugged in.</p> <p>If the pyranometer connect is accidentally damaged, contact <a href="#">Customer Support</a>.</p>

## 4.6 CUSTOMER SUPPORT

### NORTH AMERICA

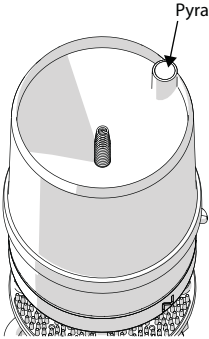
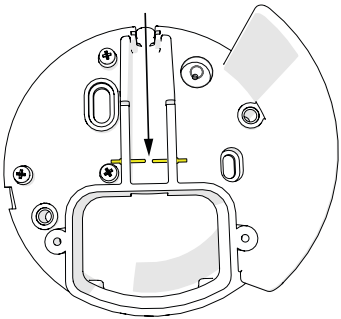
Customer service representatives are available for questions, problems, or feedback Monday through Friday, 7:00 am to 5:00 pm Pacific time.

**Email:** [support.environment@metergroup.com](mailto:support.environment@metergroup.com)  
[sales.environment@metergroup.com](mailto:sales.environment@metergroup.com)

**Phone:** +1.509.332.5600

**Fax:** +1.509.332.5158

**Website:** [metergroup.com](http://metergroup.com)

### EUROPE

Customer service representatives are available for questions, problems, or feedback Monday through Friday, 8:00 to 17:00 Central European time.

**Email:** [support.europe@metergroup.com](mailto:support.europe@metergroup.com)  
[sales.europe@metergroup.com](mailto:sales.europe@metergroup.com)

**Phone:** +49 89 12 66 52 0

**Fax:** +49 89 12 66 52 20

**Website:** [metergroup.de](http://metergroup.de)

If contacting METER by email, please include the following information:

Name	Email address
Address	Instrument serial number
Phone	Description of the problem

**NOTE:** For products purchased through a distributor, please contact the distributor directly for assistance.

## 4.7 TERMS AND CONDITIONS

By using METER instruments and documentation, you agree to abide by the METER Group, Inc. USA Terms and Conditions. Please refer to [metergroup.com/terms-conditions](http://metergroup.com/terms-conditions) for details.

## REFERENCES

- Campbell, Gaylon S. and Michael H. Unsworth. 1979. An Inexpensive Sonic Anemometer for Eddy Correlation. *Journal of Applied Meteorology*. 18 (8):1072–1077.
- Buck, Arden L. 1981. New Equations for Computing Vapor Pressure and Enhancement Factor. *Journal of Applied Meteorology*. 20 (12):1527–1432.
- Robinson, R.A. and Stokes, R.H. 1970. *Electrolyte Solutions*. 2nd ed. New York: Dover Publications.

# INDEX

- A**
- anemometer 13–19
  - applications 1
- B**
- barometric pressure sensor 19, 26
- C**
- calibration
    - frequency 26
    - initial 25–26
  - cleaning 26–28
  - communication 3, 6
  - connecting 3–6
  - customer support 30–31
- D**
- data acquisition system 10. *See also* connecting
- E**
- electromagnetic interference 2, 23
  - email address 30
- F**
- fax number 30
- I**
- installation 2–3
- L**
- lightning sensor 17–18
  - limitations 22–23
- M**
- maintenance 26–28
  - measurements
    - air temperature 8, 17, 24, 25
    - barometric pressure 8, 19, 24, 25, 26
    - humidity sensor temperature 8
    - lightning distance 9, 24, 26
    - lightning strike 9, 24, 26
    - maximum rainfall rate 24
    - precipitation/rainfall 7, 22–23, 24, 25
    - relative humidity 8, 25, 26
    - solar radiation 7, 12–13, 23, 25, 26
    - tilt 9, 19, 24, 26
    - vapor pressure 7, 14, 24, 25
    - wind direction 9, 13, 24, 26
    - wind gust 9, 13, 24
    - wind speed 9, 13, 23, 25
- P**
- phone number 30
  - pyrometer 2, 12–13, 26
- R**
- rain gauge 16–17
  - references 32
  - relative humidity sensor 14–16, 26
- S**
- sensors
    - anemometer. *See* anemometer
    - barometric pressure sensor.
      - See* barometric pressure sensor
    - lightning sensor. *See* lightning sensor
    - pyranometer. *See* pyranometer
    - rain gauge. *See* rain gauge
    - temperature sensor. *See* temperature sensor
    - tilt sensor. *See* tilt sensor
    - vapor pressure/relative humidity sensor.
      - See* relative humidity sensor or vapor pressure sensor
  - specifications
    - cable length 10
    - communication 10
    - data logger compatibility 10
    - dimensions 10
    - electrical 10–12
    - measurement 7–9
    - physical 10

## T

temperature sensor 17–18, 21–22

terms and conditions 31

theory

- air temperature 21–22

- lightning 18

- precipitation 16–17

- relative humidity 14–15

- solar radiation 12–13

- vapor pressure 14–15

- wind 13, 19–21

tilt sensor 19

troubleshooting 28–30

## V

vapor pressure sensor 14–16, 26

## Z

ZENTRA

- logger 4, 15, 23–24

- ZENTRA Cloud 4

- ZENTRA Utility 4

**METER Group, Inc. USA**

2365 NE Hopkins Court Pullman, WA 99163  
T: +1.509.332.2756 F: +1.509.332.5158  
E: info@metergroup.com W: metergroup.com

**METER Group AG**

Mettlacher Straße 8, 81379 München  
T: +49 89 1266520 F: +49 89 12665220  
E: info.europe@metergroup.com W: metergroup.de

