

CompactRotoSonic MIT08 (CRS MIT08)



CRS MITO8:

- Special foundation drilling
- Anchor installation
- Micro piling
- Compensation grouting
- Jet grouting
- Chemical injections
- Sampling
- Well installation

The CompactRotoSonic CRS MITO8 is built to perform in the most challenging and diverse working conditions. Powerful 150 Hz Sonic drill head, low centre of gravity and a movable mast make this the perfect tool for all special foundations drilling jobs.



CRS MITO8

CompactRotoSonic HO Drill head	Metric	Imperial
Max. frequency	0 - 150 Hz	0 - 150 Hz
Sonic vibration oscillator output force	150 kN	33.8 k lbf
Eccentrics	mechanically synchronized	mechanically synchronized
Rotation torque: clockwise 0-120 rpm	2.650 Nm @ 185 bar	1,955 ft-lbf @ 2,680 psi
Rotation torque: counter clockwise	3.000 Nm @ 210 bar	2,210 ft-lbf @ 3,045 psi
Head tilt max.	70°	70°
Type of damper / buffer	rubber	rubber
Mass of head	600 kg	1,350 lbf
Pull up force in combination with sonic	5.000 daN	11,240 lbf
Pull down force in combination with sonic	5.000 daN	11,240 lbf
Pull up force static	10.000 daN	22,480 lbf
Pull down force static	5.500 daN	12,400 lbf
Drilling under angle perpendicular driving direction	10°	10°

Rig	Metric	Imperial
Caterpillar 4 cylinder diesel engine Tier 4 final	110 kW	148 HP
Caterpillar 4 cylinder diesel engine Tier 3	106 kW	142 HP
Dimensions folded (L x W x H) approx.	7.300 x 2.200 x 2.590 mm	23'11" x 7'3" x 8'6"
Height (when drilling) max.	7.330 mm	24'1"
Mass	Depending on options	Depending on options
Fuel tank (diesel)	150 liter	39.6 gallon
AdBlue tank (Tier 4 engine only)	15 liter	3 gallon
Load sensing hydraulic system	Included	Included
Radio remote for all drilling and driving functions	Standard	Standard
Width undercarriage, variable	1.600 - 2.200 mm	5'3" - 7'3"
Full steel tracks	Standard	Standard
Rubber belt tracks	Optional	Optional
Maximum gradeability	50%	50%
Work lights	Standard	Standard

Mast	Metric	Imperial
Stroke (to choose)	1.300-1.900-2.400-3.800 mm	4'3" - 6'3" - 7' - 12'5"
Pull up	70 kN	15,700 lbf
Pull down	70 kN	15,700 lbf
Pull up and down speed	40 m/min	130 ft/min
Double hydraulic break out clamp	48 - 260 mm 60 - 360 mm	1.9" - 10.2" 2.4" - 14"
Adjustable clamping force of	230 kN	51,700 lbf
Break out torque	35 kNm	25,800 ft-lbf
Main winch	1000 daN, 100 m/min, 100 m	2,250 ft-lbf, 328' /min, 328'

Pumps		
High pressure water pump	19 l/min	5 gpm @ 3,045 psi
Large flow triplex water pump	160 l/min @ 45 bar	42 gpm @ 652 psi
Large flow triplex water pump	200 l/min @ 70 bar	53 gpm @ 1,015 psi
Aluminium water tank	300 liter	79 gallon

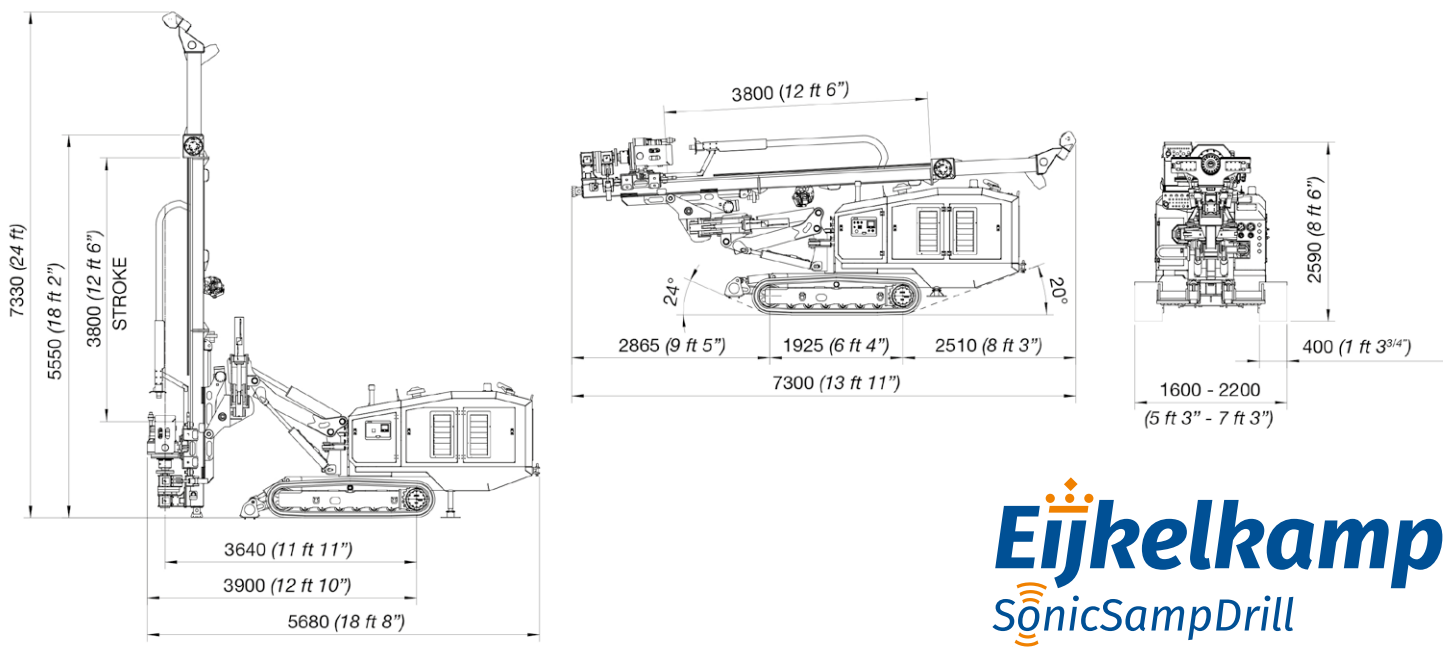



Options	Metric	Imperial
SPT auto drop hammer with blow counter		
Triple foot clamp	48 - 260 mm 60 - 360 mm	1.9" - 10.2" 2.4" - 14"
Floating top foot clamp of triple foot clamp		
Casing lifter mounted on break out clamp	200 kN stroke 300 mm	45,000 lbs stroke 12"
Safety cage		
Slewable, extendable jib boom for winch		
Mast extension for winch		

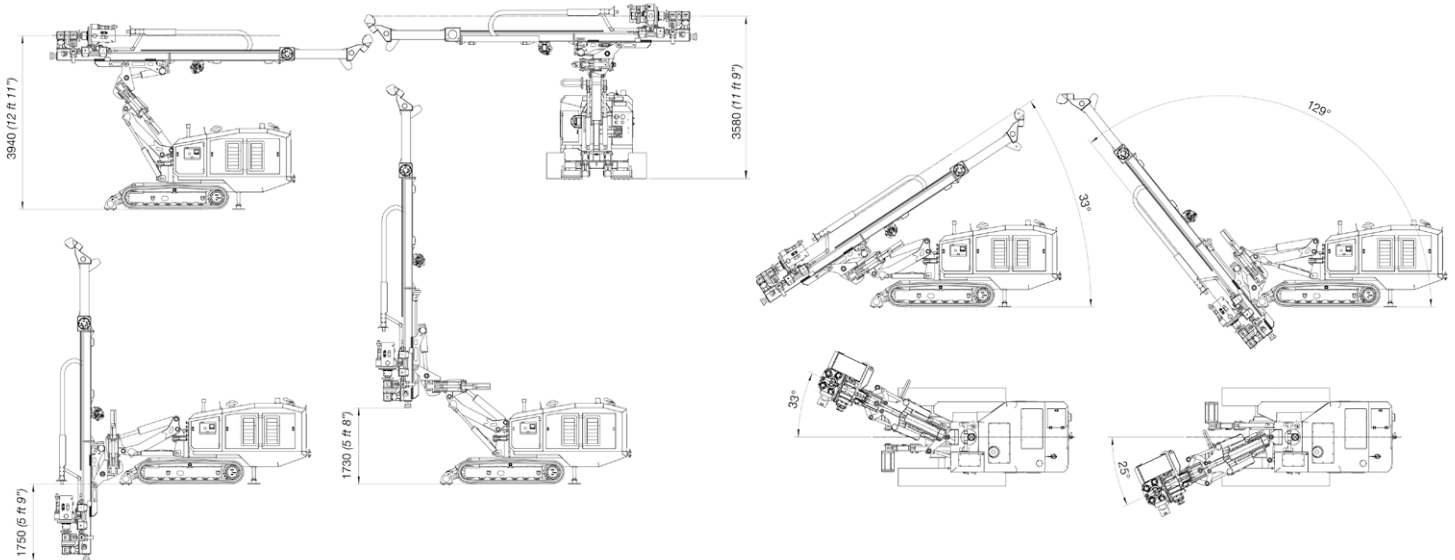

For more information on demos, pilot projects or personal advice contact our sales department !

For urgent service calls and/or technical information contact or special service telephone: +31 313 800 967



Výhradní zastoupení pro ČR a SR

K Třešňovce 700
Karlík u Prahy
Česká republika

+420 251 640 511
info@ekotechnika.cz
www.ekotechnika.cz